

Residual BER Prediction



Agilent Technologies

Predicting Residual BER II *“Measurements for Lowering Radio Cost”*

June 26, 2002

Presented by:

Kent K. Johnson

Abstract:

The demand to put more data through the channel has driven the industry to complex modulations that require low phase noise oscillators and low distortion power amplifiers. While design tools such as link power budgets are excellent for predicting performance at threshold, a different analysis is needed for ‘normal’ receive power levels. Residual bit error rate prediction allows the radio designer to determine the phase noise and linearity requirements for a given quality of service. System bit error rate performance is thus related to key analog metrics that drive cost. The recent growth of the broadband market has created much interest in this little understood topic.

Residual BER Prediction

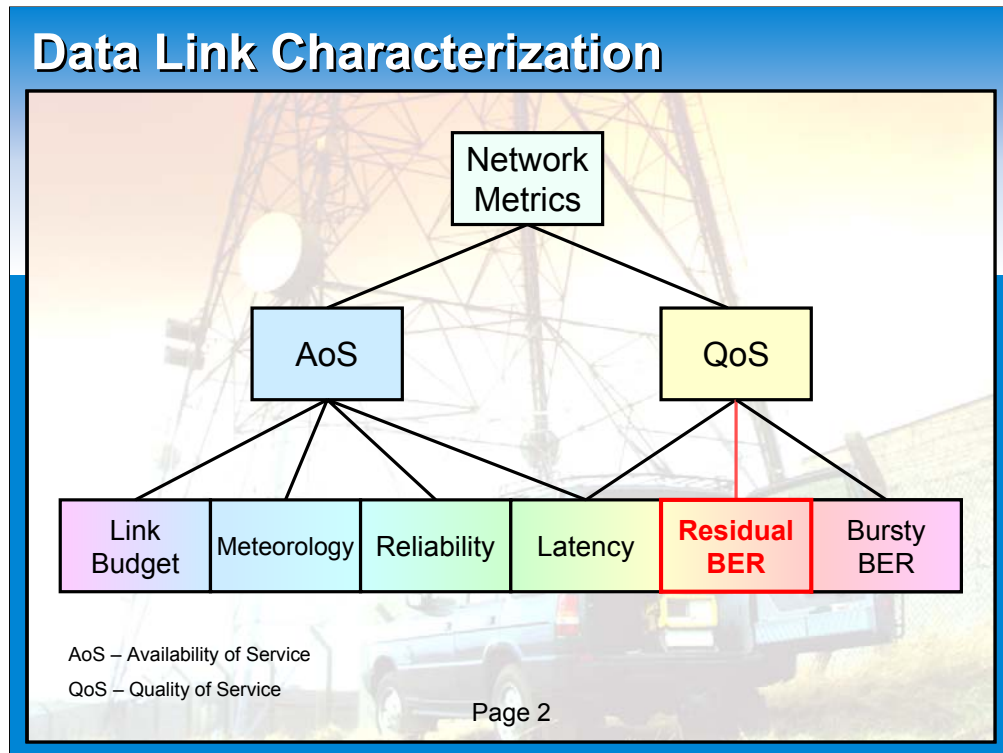

Digital network link operators have a variety of metrics used to describe the performance of their data links. In general these metrics can be broken down into two key groups, Availability of Service (AoS) or Quality of Service. Availability of Service metrics describe how often the link is considered useable and encompasses items such as local rain rates, link power budgets, as well as predicted component reliability. Quality of Service metrics define how accurately the data is received when the link is available. Is the data identical to what was transmitted? Or have some errors occurred?

This presentation focuses on a very important metric of QoS, Residual BER.

Residual BER Prediction

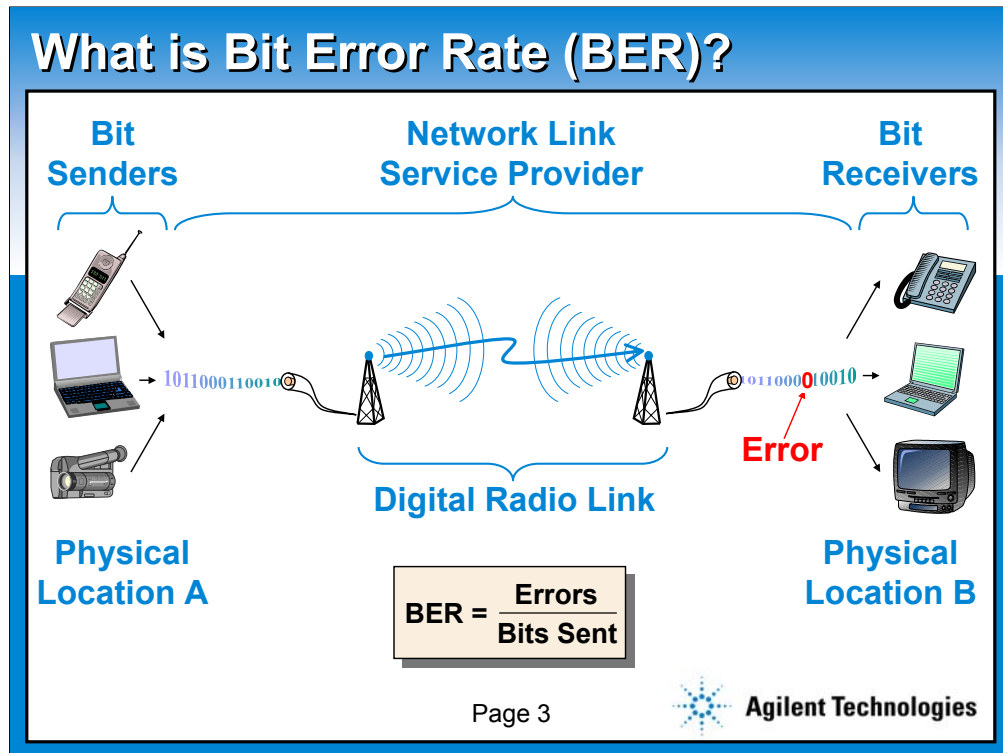

In any digital communications link there are bit senders and bit receivers that are physically separated. These devices are linked together through a network link, often provided by a third party service. The network links can be wire, coaxial cable, fiber optic, microwave or some combination.

One very important measure of the Quality of Service (QoS) of the network link provider is the ratio of bits sent correctly to bits in error. This ratio is called the Bit Error Rate or BER.

Different levels of service quality are required depending on the type of network data being transported between locations. Voice traffic will tolerate much higher error rates than data traffic. Digitized voice can tolerate bit errors as high as 1 bit per thousand bits sent or 10^{-3} BER. Computer data demands bit error rates of 1 per million to 1 per trillion or BER's of 10^{-6} to 10^{-12} depending on content. For example, internet surfing does not demand the same quality of service as bank fund transfers.

BER is an important part of the network operators service offering.

Residual BER Prediction

What is "Residual" BER?

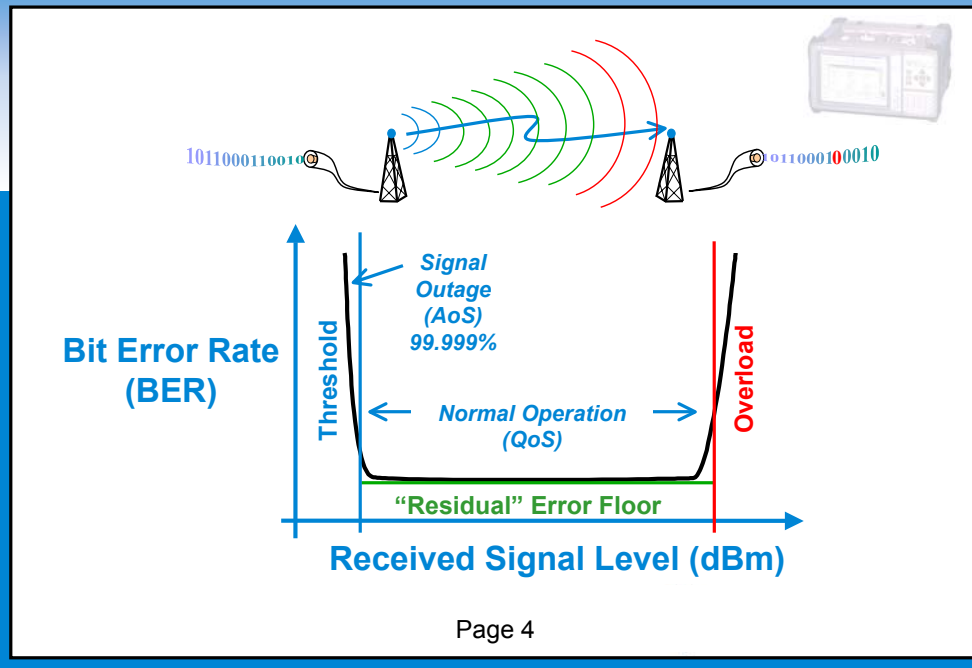

What is "Residual" BER? In a microwave data link bit error rate is a function of the Received Signal Level (RSL) sometimes called Received Signal Strength (RSS).

Very weak signals make many bit errors. The transition from few errors to many at low power is called "Threshold." A considerable body of knowledge exists on predicting threshold because it is a key factor in determining the maximum physical distance of the data link and it's availability to transport data due to atmospheric.

As received signal strength increases, the error rate will fall to a very low level or error floor. This error floor is called the "Residual" bit error rate or "Residual BER". It is the 'normal' operating performance of the data link.

As received power is increased, ultimately the receiver will reach an overload point where the error rate increases quickly.

This presentation focuses on a somewhat different approach for predicting residual BER, from those traditionally used at threshold as well as the common measurements which support the theory. Residual BER II differs from the original Residual BER presentation that focused primarily on setting up a budget, by covering the detailed practical aspects of setting up the measurements to reduce cost.

Residual BER Prediction

Who Cares About Residual BER?

Network Operators:

- A Single Measure of Broadband Radio Quality (QoS)!
- Characterizes the Radio Link's "Normal" Performance

Equipment Manufacturers:

- Determines the Requirements for Key Cost Components
- Assures Interoperability of Transmitters & Receivers
- Essential to Separating Modulator, RF & Demod Issues

Component Suppliers:

- Drives Key Specifications — Phase Noise & Linearity
- Links Analog Component Characterization to Digital BER

Why is residual BER important? The network provider's customers demand a certain quality of service based on the type of data payload being carried. The better the quality of service, the bigger the potential market. Thus the network provider uses residual BER as a measure of the quality of the equipment he has purchased.

Unlike threshold and dispersive fade margin, key availability metrics, residual BER characterizes the radio in its 'normal' operating received signal strength range. This is the performance the network provider will experience most of the time.

Residual BER budgets are an essential element for cost optimization of the sources and power amplifier, two of the most expensive pieces of any radio link.

Many vendors are now providing products with capacity upgrade paths by increasing the complexity of the radio's modulation or require interoperability between units. Residual BER prediction assures manufactures interoperability between different receivers or transmitters!

Residual BER measures the combined effect of the digital radio's modulator, transmitter, receiver and demodulator. It is thus a combined evaluation of the entire link and also drives key component specifications. The most important contribution of residual BER prediction is it relates key analog metrics to digital bit errors!

Residual BER Prediction

Residual BER Prediction

- **QAM Digital Radio**
- **Noise & Error Probability**
- **Non-Linearity Distortion**
- **System Cost Considerations**
- **Example Measurements**

- Page 6 -

This presentation is broken into five parts. First, a brief introduction to the Residual BER problem and QAM Digital Radio for those unfamiliar with the basic technology or why this subject is of such keen interest in the industry.

Next, we will review a basic noise and error probability model. This will serve as a foundation for our Residual BER budget process.

Similarly, a review of common non-linear distortion models is helpful before trying to begin to put the concepts into a composite system. This is followed by a discussion of composite effects including tips for how to optimize cost.

Finally, an example test setups are presented to tie all the material into a practical guide for setting up a test structure to support the cost and interoperability discussed earlier.

Frequently, radio engineers find they have been exposed to all this material but rarely have they seen it applied to the Residual BER budgeting process.

Residual BER Prediction

Quiz – Polling Question #1

A new wireless terminal (CPE) is added to an established operating network and it dribbles errors on the downlink. The receive signal level is checked and in the “normal” range. The base station transmitter is then backed off 1 dB and the errors stop. The problem is most likely the:

- A) receiver’s noise figure
- B) PA’s linearity
- C) receiver’s phase noise
- D) system’s residual BER budget



This polling question will help guide us in understanding the audiences knowledge of the subject and industry.

Now that you have a minute to think about it what is your answer?

Residual BER Prediction

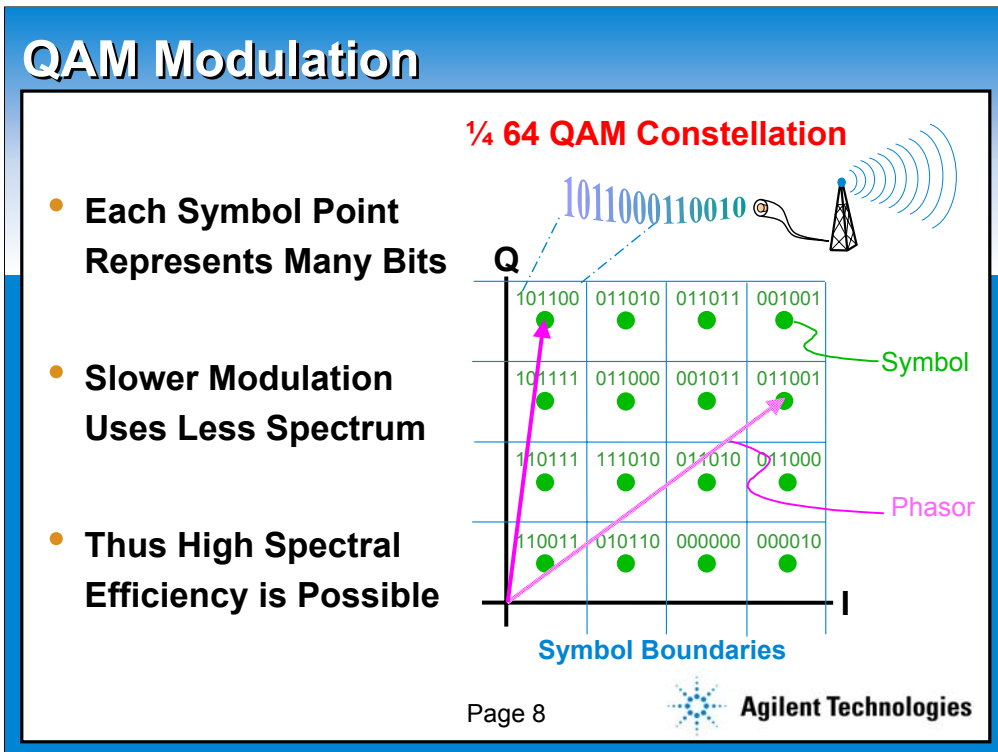

Most modern digital radios use QAM or some form of it. QAM stands for Quadrature Amplitude Modulation which is a vector modulation or Phasor modulation. It is created by taking two vectors which are 90 degrees apart and amplitude modulating them, then summing them together to form a resultant vector. The resultant vector can be modulated in both amplitude and phase.

This vector or “phasor,” can be directed to any number of points which represent a symbol constellation. Typically, the number of points in the constellation is related to a power of 2 (2^n) to make digital processing easier.

In the remainder of this paper we will use the 64 QAM symbol constellation for our examples (the techniques are equally applicable to other QAM based modulations). Often for simplicity, only a single quadrant of the 64 QAM constellation is shown.

Each symbol represents several bits, allowing more information to be sent with each sample of the vectors position. Sending several bits with each sample has the advantage of decreasing the rate the vector is modulated, thus decreasing the RF bandwidth required to transmit a given amount of information. Decreasing the RF bandwidth requirements provides high spectral efficiency which is often a concern with broadband modulations.

On the receive side the vector is matched up with the the symbol that it best fits and bit values are reassigned.

Residual BER Prediction

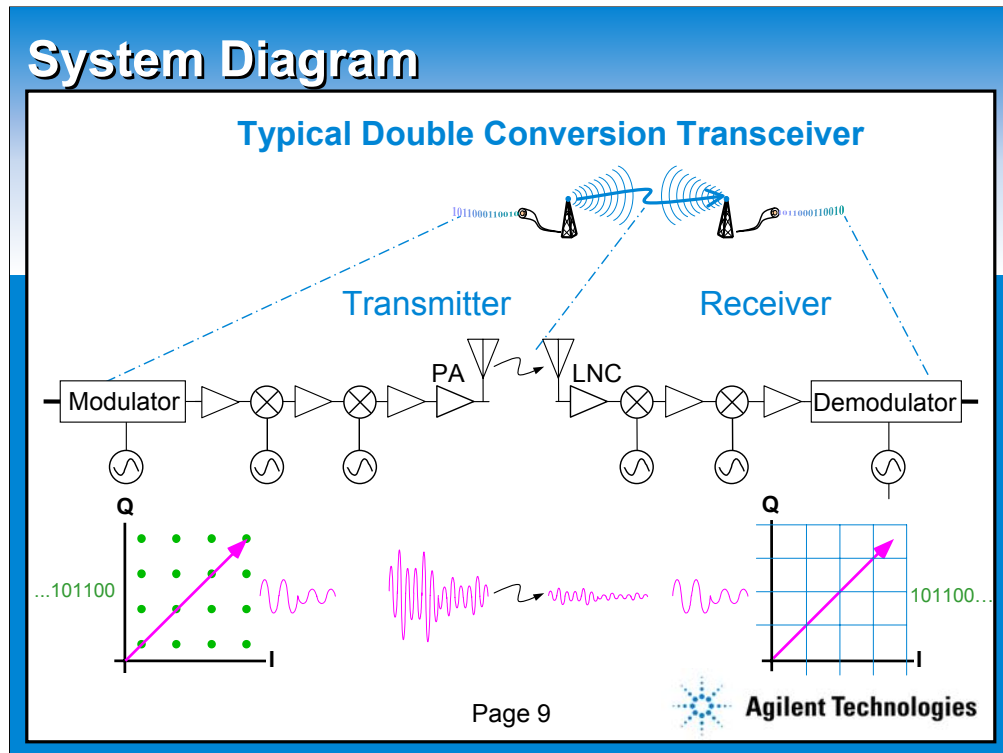

In the typical digital radio, bits come to the modulator and are mapped to a symbol point. The vector is then driven to that symbol point.

The signal then is up converted to a high frequency [filtering has been omitted] which radiates easily and where sufficient bandwidth exists to carry the required data rate. The up converted signal is boosted in power with the power amplifier [PA] and directed out through the antenna towards the receiver.

The signal then travels to the receiver suffering attenuation and some distortion from the path.

Upon receiving the signal it is amplified and down converted to a frequency where signal processing is least costly. The demodulator then compares the phase and amplitude of the vector and makes a decision on which symbol best fits, followed by assigning the representative bits.

Residual BER Prediction

Types of Receive Problems

- Ideal Symbol Point



- Random Noise



- Phase Noise



- AM/AM Distortion



- AM/PM Distortion



- Delay Distortion



- Interference



64 QAM Constellation

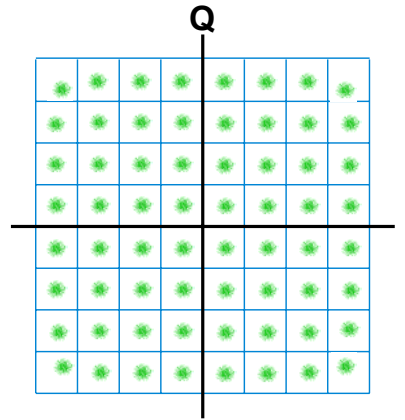

Page 10



Agilent Technologies

Ideally, at the receive demodulator a single infinitesimally small sample point would be found in the center of the symbol boundary area. Unfortunately, this never occurs because there is always noise, distortion and interference components present.

Random noise has the effect of creating a distribution of sample points. Phase noise is similar to random noise but is only on the angular axis.

AM/AM distortion causes the symbol point to fall short of the desired point on the radial axis based on vector length. AM/PM distortion causes the symbol point to take on an angular error based on the vector length

Delay distortion [sometimes call inter symbol interference, ISI] causes the symbol point to be distorted based on the previous symbol point.

Finally, spurious interference will cause the point to take on a circular shape.

These are all unwanted signal impairments which make the symbol decision process imprecise and result in bit errors.

Residual BER Prediction

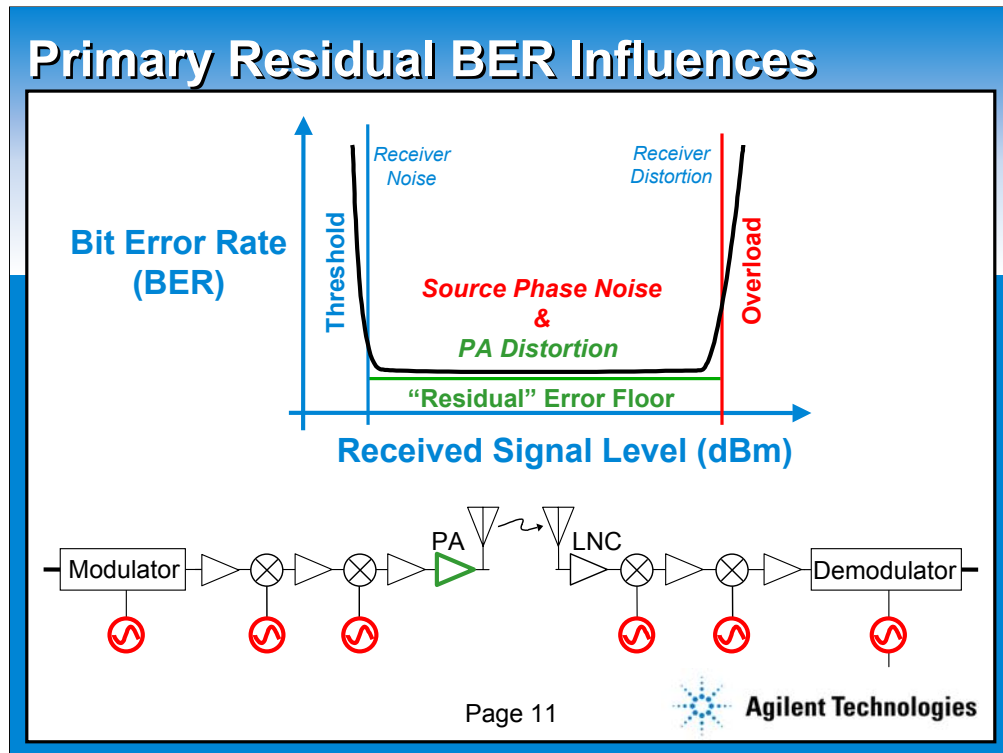

Many of these signal impairments are dominated by several key system elements. Generally, they fall in two categories, noise sources and distortion sources.

Local oscillators used for modulation and demodulation as well as the up and down conversion are primarily responsible for the phase noise component. Similarly, receiver noise figure is a primary cause of the random noise.

The transmitter power amplifier and receiver first mixer are the most common sources of distortion components, such as AM/AM and AM/PM.

Each of these sources of constellation problems has a unique impact on the BER performance. At threshold, receiver noise dominates the BER error mechanisms. At overload, receiver distortion, primarily in the first mixer, dominates the BER error mechanism. The residual error floor is dominated by a combination of the phase noise from all the sources and the PA's distortion!

The remainder of this presentation will focus on the residual BER floor. It is important to note that the techniques to follow, are equally applicable to overload and threshold. The dominant component(s) of error differ based on the received signal level. Thus, the error versus received signal level curve is really made up of three composite terms (threshold, residual & overload) influenced by a variety of component factors.

Residual BER Prediction

Residual BER the Key to Cost!

- The components that determine the “Residual BER” often account for **60+%** of the radio cost!
- The economics of the phase noise & linearity tradeoff directly effects your product’s success!

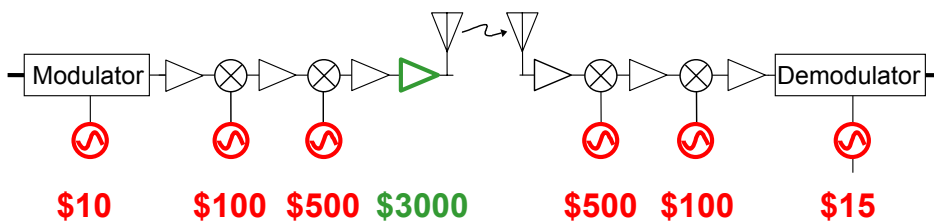

Page 12



Considerable interest in the subject of Residual BER has developed over recent years, corresponding to the increasing usage of complex modulations. Why?

One very important reason is that the components which effect the residual BER often represent the majority of the cost of a broadband wireless link (Typically 60% or more of a radio cost is in the sources and power amplifier)! More and more companies are realizing that a clear understanding of the possible component tradeoffs when it comes to the residual BER, is essential to minimizing cost.

Thus, the economics of residual BER, particularly phase noise and linearity, can make or break your product success in the market place!

Residual BER Prediction

Residual BER Assures Interoperability!

- System that are deployed over a period of years require interoperability specifications!
- The Residual BER Budget is key to assuring interoperability QoS for CPE & handsets!

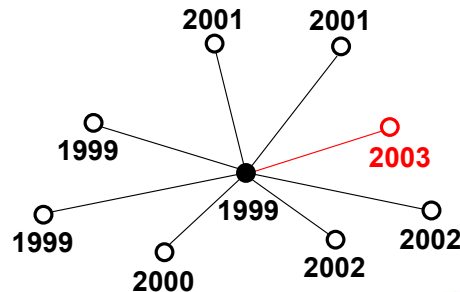

Check the
Polling Results!

Polling

CPE – Customer Premise Equipment

Page 13



Agilent Technologies

Another important reason residual BER budgeting is becoming popular is that many of today's systems require transmitter and receiver interoperability to be engineered into the data link. As the progression from simple voice radio traffic to data continues, the tolerance for bit errors also continues to decrease. Since most large scale systems are deployed over a period of time, it is essential that there is some engineering guarantee that a future receiver will operate with today's transmitter and vice versa.

Though there are many other performance metrics, only the residual BER budget can assure high quality error free performance between units. Thus a sound residual BER budget is key to assuring interoperability for Customer Premise Equipment (CPE) or even handsets.

Yes, even the cellular industry is examining residual BER budgeting. As phones transition to data intensive uses such as map downloads and pictures, that require longer and longer synchronization overhead, the tolerance for high BER and resending packets is decreasing rapidly. Add to this the extreme price pressure of the industry, and what was once the realm of high end expensive point to point backhaul communications is now of interest to that industry as well.

Residual BER Prediction

Residual BER Separates Problems!

- System BER performance is the summation of modulator, RF & demodulator performance!
- The Residual BER Budget is essential to determining which component is not working!

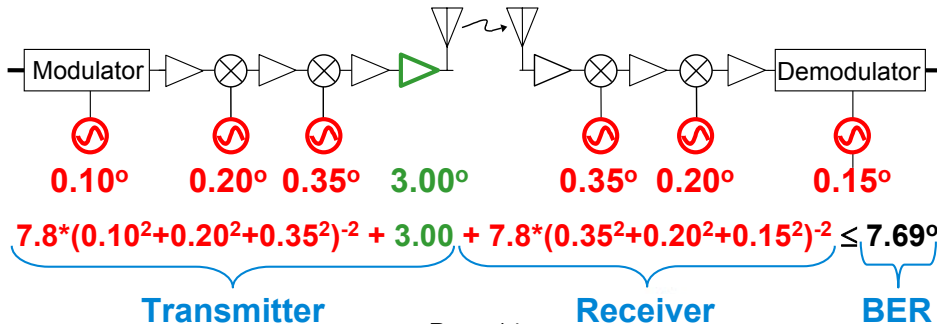

The ability to separate problems is also another reason that there is considerable interest in the residual BER subject.

The residual BER is a function of components spread across the system. Modulators, up converter sources, power amplifiers, down converter sources and demodulators all combine to determine the residual BER! At systems level, connection of a Bit Error Rate Test set (BERT) easily determine if the BER is acceptable, but when it is not, the question then becomes what is causing the problem?

The only way to determine, “which straw broke the camel’s back,” is to have a careful allocation of the permissible signal impairment by each component.

As illustrated above, the angular error introduced by each component must be less than the maximum angular error permissible for the symbol point, else the radio will make errors at an unacceptable rate! So to determine which component is at fault, it is essential to have a worst case budget for each!

Having such a budget is often very helpful from an organizational point of view, since typically the different disciplines are the basis for organizing different departments, eliminating considerable departmental bickering.

Residual BER Prediction

Important Assumptions: Group Delay

- **Filters Introduce Group Delay**
- **Spectral Content Varies with Phase Change Size**
- **Phasor Angle is Modulated from Delay or Dispersion**
- **Phasor Modulation Based on Symbol Sequences! (ISI)**
- **Assume Digital Equalizers Eliminate this Problem!**

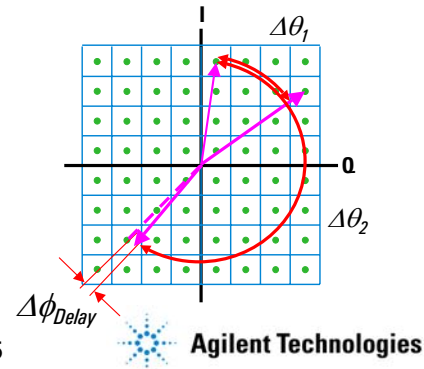
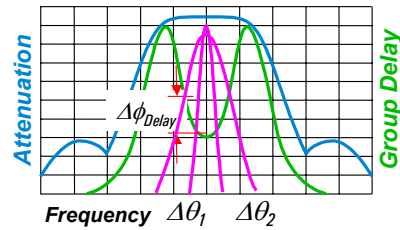

Page 15

In our discussion of residual BER we have made some key simplifying assumptions, one of which is that group delay is not a significant factor in the residual BER budget. This is often, the case for modern systems which have a powerful digital equalizer, but let's briefly review the subject.

Filters introduce group delay into the modulated channel. The spectral energy associated with a change in phase is dependent on the magnitude of phase modulation. Small changes in phase occupy small bandwidths, large changes in phase occupy larger bandwidths.

The delay difference associated with the two spectrums produces a phase error on the modulation vector. This error is based on what the previous symbol sequence was and is another way of looking at inter symbol interference (ISI).

Fortunately, for most modern digitally equalized radios the equalizer reduces this error to an insignificant portion of the residual BER budget and it can be ignored. If your system does not have such an equalizer, these effects must be added to the residual BER budget and are beyond the scope of this paper.

Residual BER Prediction

BER vs. Spectral Mask Limited

- Two Types of Radios:
 - BER Limited
 - Spectral Mask Limited
- Increasing PA Non-linearity Causes:
 - BER to Become Excessive
 - Spectral Re-growth to Impinge the Mask
- Dependent on Base-band Filter Design

BERT

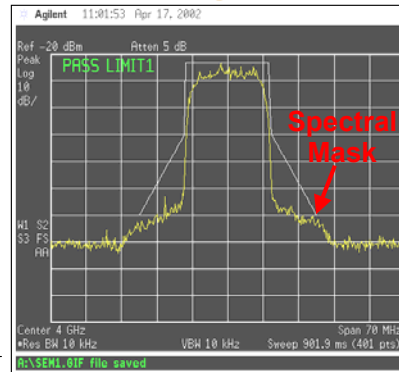

- Page 16 -

Another important assumption is that the radio link in question is BER limited? There are fundamentally, two types of radios, BER limited and spectral mask limited.

As the power amplifier linearity is increased the signal impairment generally cause two things to go wrong, the BER increases and the transmit spectrum sidebands begin to grow. This will ultimately cause one of two problems, either the BER becomes unacceptable to the user or the spectral "re-growth" impinges on the regulatory spectral mask to the point the transmitter emissions are no longer legal.

If the BER becomes excessive first the radio is said to be BER limited. If the spectral mask is impinged, the radio is said to be spectral mask limited. Generally speaking applications where the data is of high value or critical, require low residual BER and radios are engineered to be BER limited. Inexpensive radios used in applications where BER is not a factor, often are spectral mask limited.

It is interesting to note that the key technical difference between radio types is usually the performance of the base-band filters. If the base-band filters "push" the sideband energy down far enough there is more room for it to grow before it reaches the mask, consequently, BER will likely degrade first.

In this presentation we have assumed that the radio in question is BER limited.

Residual BER Prediction

Residual BER Prediction

- QAM Digital Radio
- **Noise & Error Probability**
- Non-Linearity Distortion
- System Cost Considerations
- Example Measurements

Page 17

Now that we have had a brief review of QAM radio and residual BER issue, let's examine a common noise and error probability model applied to BER.

Residual BER Prediction

Error Probability

- Errors Occur When the Received Phasor Sample Falls Outside a Symbol Boundary
- The Area Under the pdf Beyond the Symbol Boundary Represents the Probability of an Error
- Error Probability is Based on the Number of Standard Deviations to the Boundary

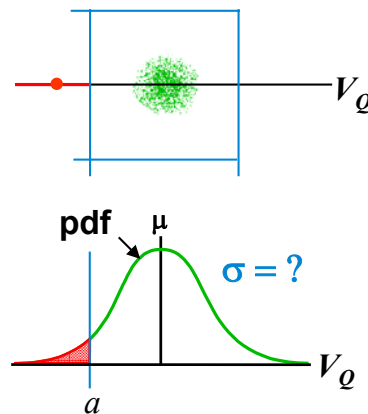

$$P(V_Q < a) = \int_a^{-\infty} \frac{1}{\sqrt{2\pi\sigma^2}} \exp\left[-\frac{(v_Q - \mu)^2}{2\sigma^2}\right] dv_Q$$

Page 18

Errors occur when the received phasor sample falls outside the intended symbol boundary. The addition of gaussian noise creates a distribution of sample points about the mean or "ideal" symbol point. If sliced on a single axis the probability density function (pdf) is clearly visible. This distribution is similar to the "bell shaped curve" of test scores.

The pdf area under the curve beyond the symbol boundary represents the probability of that type of error. The probability can be calculated by integrating the area from the symbol boundary to minus infinity.

The central limit theorem can be used to normalized the curve to a Gaussian probability density function where the "standard deviation" (σ) is used to determine the probability of an error. Error probability can then be expressed in terms of the standard deviation of samples. Thus, the primary question becomes how many sigma (σ) are there to the symbol boundary?

Residual BER Prediction

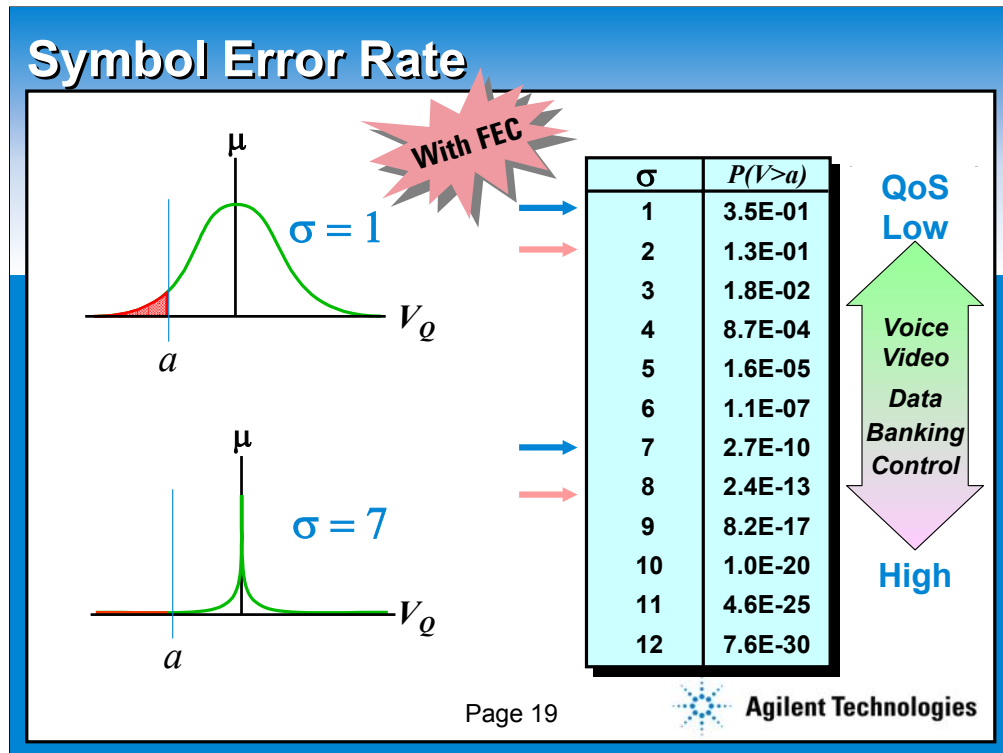

Counting the number of standard deviations to the symbol boundary provides a means to determine the probability of a symbol error.

If there is only a single standard deviation to the symbol boundary ($\sigma = 1$), then the probability of that boundary error is 3.5×10^{-1} or 35%. If there are seven sigma to the boundary ($\sigma = 7$), then the probability of an error is 2.7×10^{-10} , which is quite small.

In practice, many higher performance wireless broadband systems compete with the low end of the fiber optic communications. Often these broadband systems are held to the same QoS requirements as the fiber, where residual BER rates of 10^{-12} are common place. Raw uncorrected BER rates of 10^{-10} are usually sufficient to achieve 10^{-12} after correction, thus providing a wireless service of the same quality as that of the fiber. The typical number of sigma to the boundary for a high quality wireless system is usually between 7 and 8.

(Note: The above paragraph is the only place in this presentation where the effects of FEC are discussed. The remainder of the discussion deals with raw uncorrected error rates.)

Residual BER Prediction

Phase Noise Effects

- **Threshold Noise is Random in All Directions & Only Relevant at Low Power**
- **Oscillator Phase Noise is Random on the Angular Axis & Always Present**
- **Errors Can Occur on Both Symbol Boundaries!**

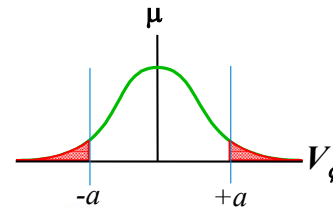
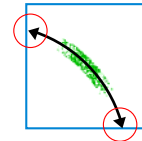
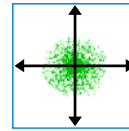

Page 20



The preceding discussion was for a simplified random noise model often found in textbooks for the analysis of threshold noise. This model is the basis for threshold effects which are random in all directions and only relevant at low power.

This presentation is concerned with "normal" operating power levels where oscillator phase noise is the dominate source of noise. Local oscillator phase noise is always present and unlike threshold noise is random on the angular axis.

The preceding analysis was simplified to examine only a single type of boundary error. In reality, errors can occur on both symbol boundaries, so a "two tailed" probability model is required. The integration of both "tails" is sometimes seen as a 3 dB factor.

Residual BER Prediction

Standard Deviation & RMS Noise

$$\sigma = 1 \Leftrightarrow \text{RMS}$$

A key relationship essential to realize is, that the one sigma distance happens to be identical to the RMS error!!! Often statistics courses are taught in such a way that connection between RMS and sigma are never clearly stated to the engineer.

If there is one element of this presentation to come away with, if you don't already know it, it is this relationship between sigma and RMS. As we will see, this relationship makes it possible to calculate the probability of a BER from analog metrics!

Residual BER Prediction

RMS Phase Noise

- **Single Side-band Phase Noise is a Measure of the Sources Spectral Purity**
- **Side-Band Noise Power Must be Integrated to Obtain Phase Noise ($\Delta\phi_{RMS}$)**
- **$\Delta\phi_{RMS}$ is the Root Mean Square Angular Deviation**
- **Integration Limits:**
 - **Start = Recovery Loop BW**
 - **Stop = Symbol Rate BW**

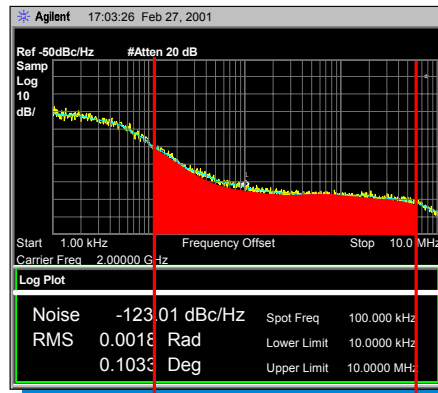

f_1

f_2

$$\Delta\phi_{RMS} = \sqrt{\int_{f_1}^{f_2} 2 \cdot \mathcal{L}(f_o)^2 \cdot df_o}$$



So how does one characterize and account for phase noise in the probability model? First, we must understand that phase noise is a measure of the source's (local oscillator's) spectral purity or how perfect the sine wave is produced.

Frequency (f) is the rate of change of phase with time. Phase noise is the deviation in phase from the mean rate of phase change (center frequency). Side-band noise power is rarely flat Gaussian with frequency offset and thus it must be integrated to obtain phase noise.

The random nature of side-band noise necessitates the need for a root mean squared (RMS) characterization. Hence, by integrating side-band noise (the difference between the mean power and the side-band power, dBc) in an RMS fashion, phase noise is expressed as an RMS angular error in either degrees or radians.

It is important to note that the limits of integration should start just outside of the carrier recovery tracking loop bandwidth for the lower limit and stop at the symbol rate bandwidth for the upper limit.

Residual BER Prediction

Phase Noise & Error Probability

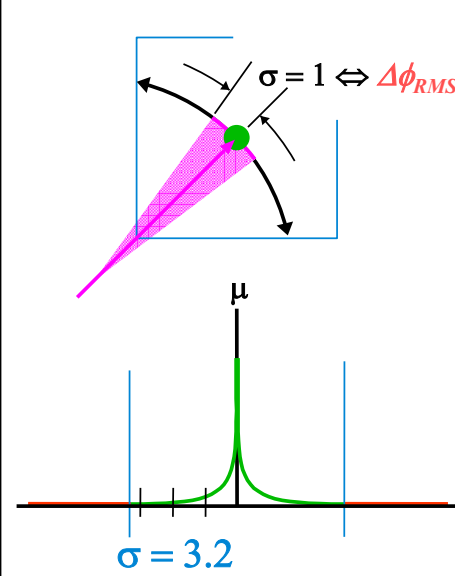

- $\Delta\phi_{RMS}$ is Integrated Side-Band Noise Power!
- The Standard Deviation Angle $\sigma = 1 \Leftrightarrow \Delta\phi_{RMS}$
- Geometry Allows the Number of σ to Boundary to be Calculated
- Normalized pdf Yields Probability of Error!

- Page 23 -  Agilent Technologies

Integrating side-band noise power over the appropriate limits gives us the RMS angular phase noise in degrees ($\Delta\phi_{RMS}$) that will effect the modulation.

This RMS error ($\Delta\phi_{RMS}$) represents the amount of angular degrees that are contained in one sigma ($\sigma = 1$) of "standard deviation!"

Knowing the angular magnitude of the one sigma and the constellation geometry it is possible to calculate the number of sigma to the symbol boundaries.

Given the number of sigma to the boundary, the normalize pdf yields the probability of that boundary error! Thus it is possible to calculate the probability of a symbol error for each possible boundary error types in the constellation. Thus the effect of oscillator phase noise on residual symbol errors can be calculated!

Residual BER Prediction

Residual BER Prediction

- QAM Digital Radio
- Noise & Error Probability
- **Non-Linearity Distortion**
- System Cost Considerations
- Example Measurements

- Page 24 -

Having reviewed QAM digital radio concepts, a basic noise model and the extension of that noise model to phase noise, let's now examine non-linear distortion as it applies to residual BER. As with the noise case, we will start by reviewing common non-linear models and then focus on those which are best for solving the problem of predicting residual BER.

Residual BER Prediction

Audience – Polling Question #2

What linearity metric do you use most often?

- A) P_{sat}
- B) $P_{1\text{dB}}$
- C) 3rd & 5th Order IMD or TOI
- D) AM/AM & AM/PM
- E) ACPR
- F) EVM



Q & A Break?



Residual BER Prediction

Linearity & Common Metrics

- Linear Amplification
- Saturated Power
- Gain Compression
- Power at 1 dB of Compression
- Two Tone Intermodulation (IMD)
- 3rd & 5th Order Products
- Third Order Intercept Point

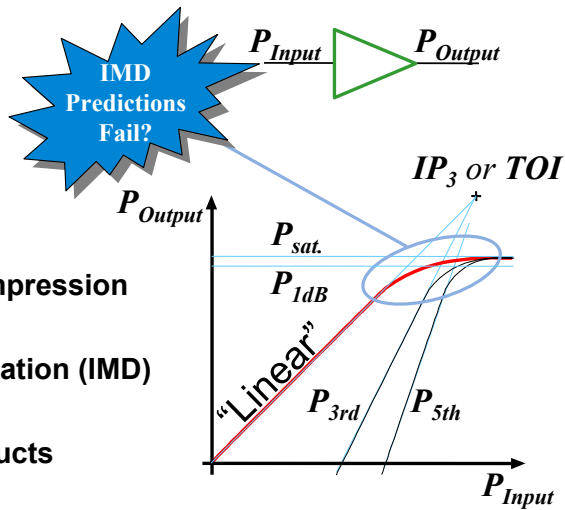

Page 26



Agilent Technologies

At low power levels amplifiers exhibit linear behavior, such that small signals are amplified by a fixed amount of gain. Given some power input the amplifier is said to behave linearly if the power output is a fixed ratio larger. As the input signal grows larger a point is reached where the output signal will stop getting bigger, the amplifier is said to be saturated and the linear relationship between input and output no longer exists. Many measurements have been devised to characterize this phenomenon.

Gain compression is a term used to describe the difference between the saturating amplifier's performance and the theoretically ideal performance. So called P_{1dB} is a measure of the output power at 1 dB of gain compression.

Two tone intermodulation (IMD) is a measurement designed to predict the amount of unwanted modulation energy created by the nonlinear saturation process. It measures the 3rd or 5th order intermodulation products. A third order intercept point can be calculated from the 3rd and 5th order products, which is helpful in predicting the level of intermodulation distortion.

Though commonly used, none of these linearity metrics is ideally suited for predicting the residual BER because PA's are operated in a region where an abrupt change in device linearity occurs where IMD and TOI measurements fail.

Residual BER Prediction

Amplitude & Phase Distortion

- Gain Compression as Power Increases is AM/AM
- Phase Change as Power Increases is AM/PM
- These Distortions are Unwanted Modulations!
- AM/PM Occurs Before AM/AM

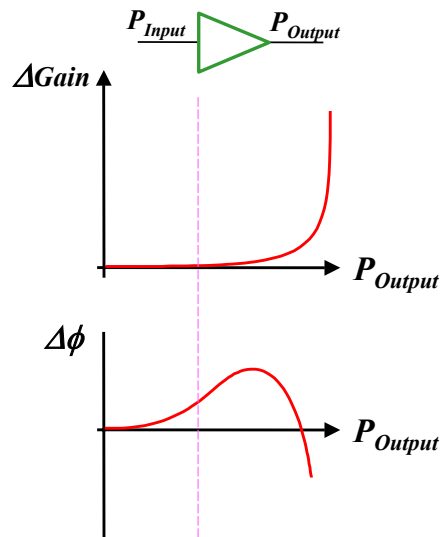

Page 27



Agilent Technologies

To predict residual BER, linearity metrics that directly relate to the QAM vector in amplitude and phase are needed. Gain compression or the difference between the ideal linear gain and the actual gain is amplitude modulation due to amplitude modulation conversion (AM/AM).

As power is increased the phase delay through an amplifier begins to change as it nears saturation. This change in phase shift as the power is increased or modulated is AM/PM modulation. As we will see later, this modulation is additive to the QAM vector.

AM/AM and AM/PM are unwanted modulations that effect the accuracy of where the symbol point position on the constellation falls.

The two graphs show the distortions in relation to each other (i.e.. same power scale). Note that significant phase shifts occur before significant amplitude shifts. Typically only a few tenths of a dB of AM/AM occur when several degrees of AM/PM have built up. The QAM modulation is much more "sensitive" to the AM/PM distortion and a few degrees of distortion are quite significant, where as 0.1 to 0.3 dB of AM/AM has little effect. This phenomena allows a key simplifying assumption that AM/AM is a secondary effect and can be ignored in our analysis. (For highly accurate BER prediction it maybe necessary to account for AM/AM.)

Residual BER Prediction

Amplifier Model

- GaAs FET Voltage to Current Characteristic
- Supply Limited Power Constrains FET Temperature
- Excessive Heat Causes Rapid Defect Migration Destroying the Device!

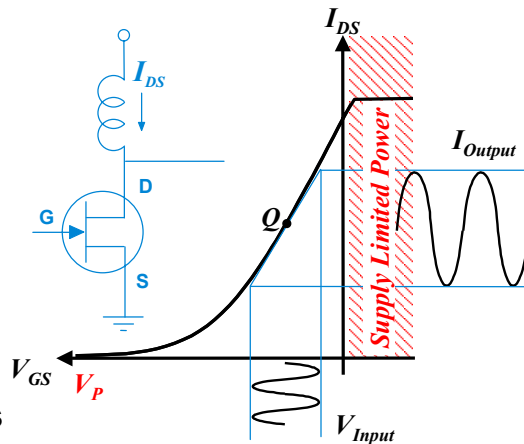

Page 28



Agilent Technologies

Sometimes it is helpful to review the mechanisms that actually generate these unwanted distortions in the power amplifier. Let's use a simple GaAs MESFET model to illustrate the principles. To keep it simple we have omitted the effects of microwave matching circuits that are of finite bandwidth and linear in nature.

The GaAs FET voltage to current characteristic behaves as a square law device. If driven with a small signal input voltage, then current is modulated about the Q point on the output. Typically, most QAM microwave power amplifiers are built as "class A" designs for maximum linearity.

The raw DC power supplied to the FET to establish the Q point must be limited to constrain the devices operating temperature. Constraining the devices operating temperature slows the semiconductors defect migration to assure a long operating life.

Next, let's see how IMD products, AM/AM and AM/PM are created in the device.

Residual BER Prediction

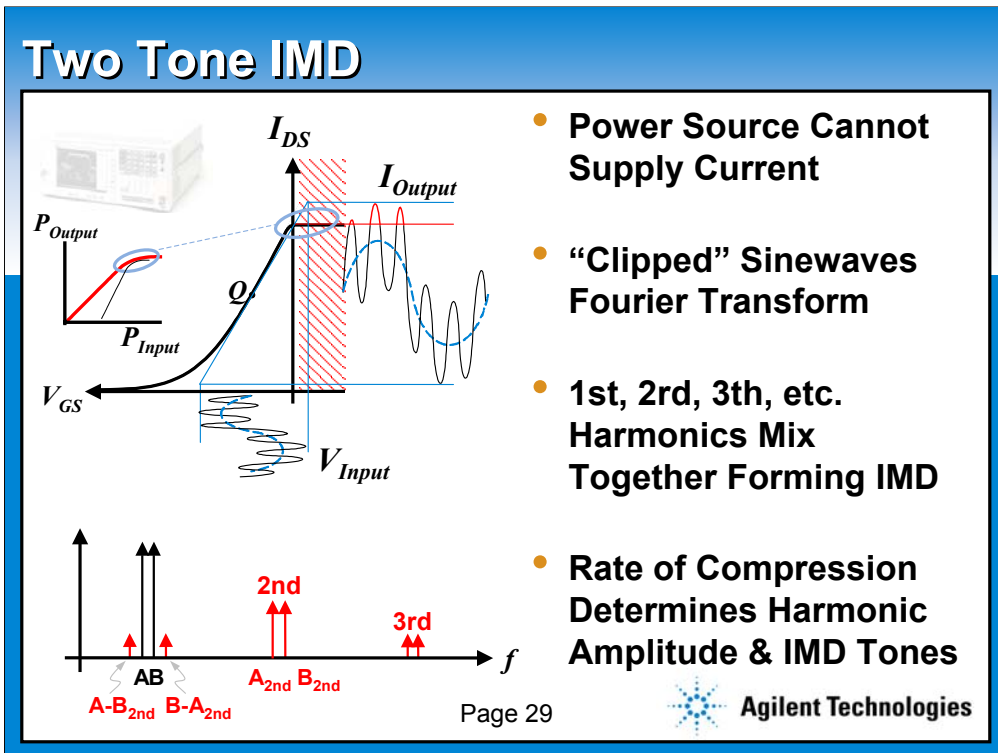

In a two tone IMD test, identical amplitude tones separated slightly in frequency are injected into the input of the amplifier. The power supply cannot deliver additional current so the superimposed sine waves are “clipped.” This gives rise to 2nd, 3rd etc. harmonics which mix together forming the IMD products.

This mixing action actually takes place in the junction of the device and often the harmonics are substantially attenuated by the band limited output matching networks. Thus it is often not possible to directly compute the intermodulation products using the measured harmonic power for microwave amplifiers. It is however a simple process to measure the relative attenuation of the IMD products with a spectrum analyzer.

Does saturation really produce such an abrupt clipping of the two sine waves? Well, that depends very much on the particular FET and how it is biased. Forward gate rectification can be very abrupt, whereas pinch off or the square law curve are much more subtle saturation characteristics. Hence the amount of harmonic energy available to be converted into intermodulation products is very dependent on the abruptness of the non-linearity! Here lies the major problem with using IMD to predict BER from correlation studies. The IMD measurement is just a single point on the P_{Output}/P_{Input} curve and only predicts linearity for small signal characteristics, but QAM modulation operates over a range of vector amplitudes near saturation that include abrupt changes in linearity.

Residual BER Prediction

AM/AM Mechanism

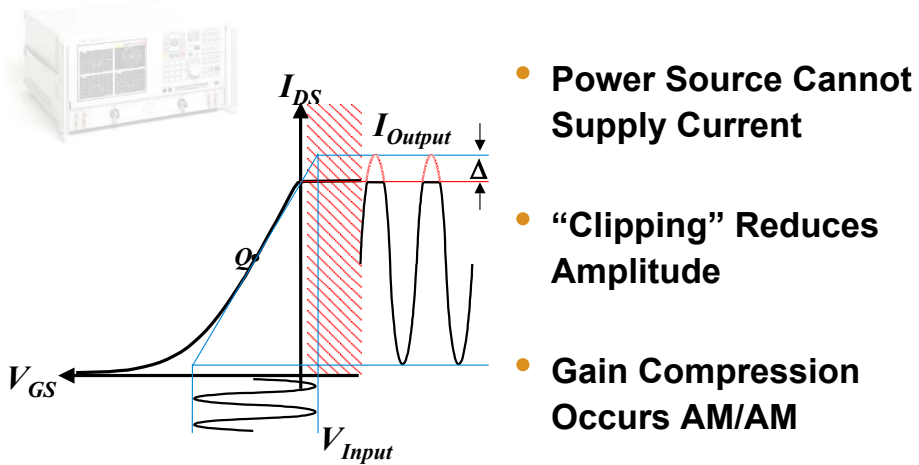

Page 30

 Agilent Technologies

The AM/AM mechanism is very simple to examine with our amplifier model. If we put a single sine wave into the amplifier and the power source cannot supply the necessary current resulting in clipping the amplitude of the output is reduced. This reduction is gain compression or AM/AM.

AM/AM is easily measured with either a source and spectrum analyzer or a network analyzer.

Residual BER Prediction

AM/PM Mechanism

- Power Source Cannot Supply Current
- “Clipping” Amplitude Changes Average Offset
- New “Zero Crossing” Offset Creates AM/PM

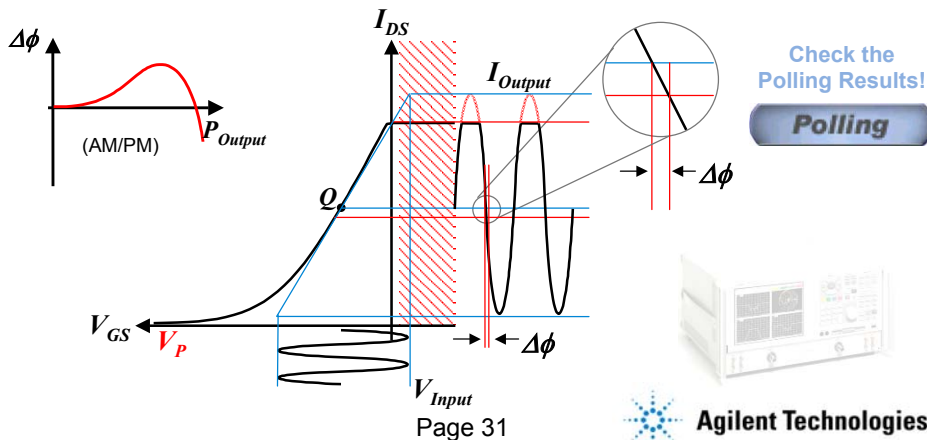

The phenomena that gives rise to AM/PM again begins with the power source limitation creating a clipping or “mushing” of the waveform. Since the top of the waveform is not correctly amplified, the average value or “zero crossing” is offset from the original position. This offset in “zero crossing” occurs where the sine wave has finite slope creating a phase shift in the output signal.

It is interesting to note if the input signal is increased still further, ultimately clipping on the bottom of the sine wave (V_p) would occur as the output begins to resemble a square wave. Clipping on both ends causes the average offset to come back towards that of the original sine wave; Hence, the characteristic rise and fall of the AM/PM curve.

It is also important to note that the microwave matching circuits strongly effect the impedance, hence the voltage and current relationship as well as the clipping on the output of the device is effected.

If one would like to develop a practical feel for these effects, consider taking a vector signal analyzer and set it up for a power sweep to measure AM/PM (discussed later in the paper) of a low frequency IF amplifier (70 – 310 MHz) Then carefully connect a high speed oscilloscope in parallel with the network analyzer, one channel being the input and the other being the output. Slow the sweep down and the clipping effects and AM/PM characteristics are readily visualized.

Residual BER Prediction

AM/PM Effect on QAM

- Phase Rotation as a Function of Vector Length
- Outer Symbols Have Largest Vector & AM/PM
- AM/PM Relates a CW Test to Modulated Signals!

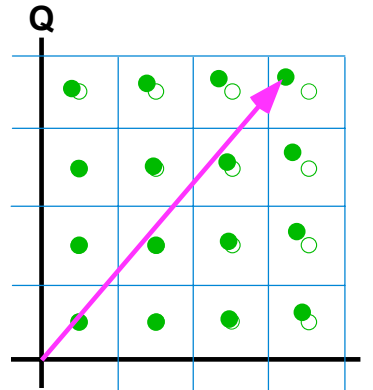

The AM/PM phase shift as a function of signal amplitude or vector length distorts the ideal symbol location of the QAM symbol constellation.

Outer symbols have the largest vector length and suffer the most AM/PM distortion.

AM/PM testing is typically done with a CW sine wave (though it possible to measure it with a modulated signal and Vector Signal Analyzer, VSA). This is an important fact because it relates a CW parametric test to the actual distortion impairment of the QAM symbol constellation!

The ability to relate a parametric analog test to the actual error mechanism provides the means to predict digital error rates from traceable standards.

Residual BER Prediction

Modulated Power Levels

- Power Meter Measures?
- Average CW Power &
- Average Modulated Power
- Peak Symbol Power
- Overshoot Power
- Need Correction Factors!

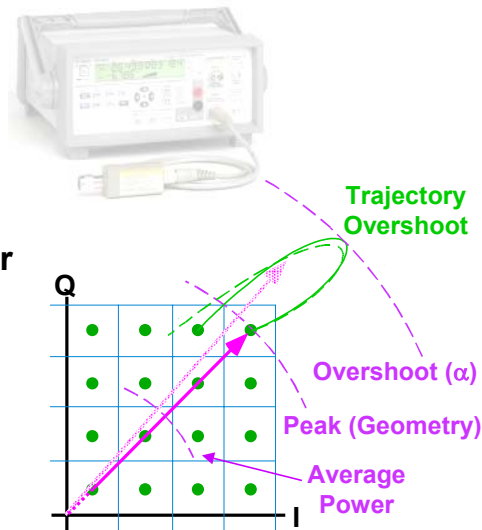

Page 33



Agilent Technologies

So how does one relate the vector length to known traceable standards? And what range of vector lengths do we need to measure the distortion over?

What do the power meters we used to setup our transmit power actually measure? A power meter measures the average CW or modulated power. Testing AM/PM with a CW source requires relating the average modulated power to the average CW power.

At first glance, this can be done by using the constellation geometry to calculate the average vector length. But, the worst case AM/PM occurs at the longest vector length or peak power. Calculating the peak to average ratio from the constellation to correct the measured average power is an important step for determining what CW test signal power is necessary for AM/PM testing.

A peak to average power correction is only one part of the determining the highest power to test AM/PM at. In between symbol states the vector overshoots the boundaries of the constellation. The so called "overshoot power" or "trajectory power" represents the longest vector length. Though understood, the overshoot phenomena is beyond the scope of this paper, so for our purposes let's simply say it is a function of the base band filtering α .

Residual BER Prediction

Test Conditions

- Measure Gain & Phase at Different Output Powers
- Test Over Vector (Phasor) Range for $\Delta \phi_{Distortion}$
- Vector Range \Rightarrow CCDF

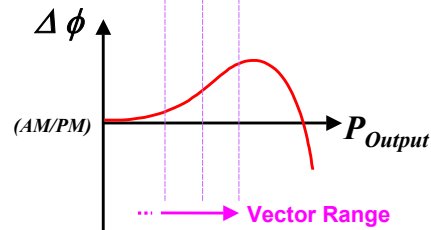
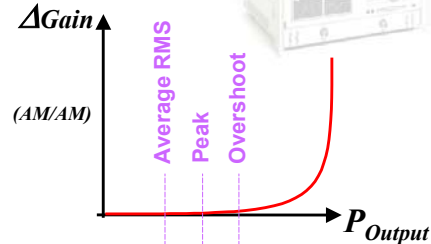
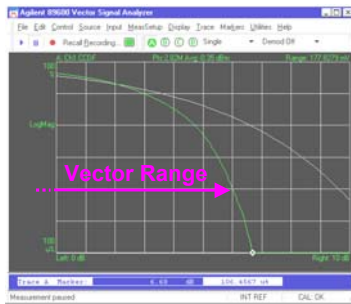

Page 34



Agilent Technologies

What test conditions are necessary to properly characterize the distortion of the power amplifier? The gain and phase distortions need to be characterized over the range of modulation powers. This means that AM/PM should be tested from the smallest vector needed to produce the modulation, to the largest vector or in other words, over the “vector range.”

Correction factors for peak to average and overshoot powers, typically about 3 dB each, must be added to the average power to come up with the overshoot power. Similarly, minimum to average power can be subtracted from the average power to determine the lowest power required. In practical terms the low power limit can be set to where no appreciable AM/PM modulation is observed, eliminating the need to calculate minimum to average.

The important thing is that we actually measure the amplifiers linearity at the overshoot power where the distortion will be the most significant. Testing at average power (what the power meter measures) would be very misleading.

One approach to determining the appropriate vector range is to measure the complementary cumulative density function of the modulated signal. This vector signal analyzer or spectrum analyzer (VSA) measurement shows the overshoot or trajectory vector length as a function of probability.

Residual BER Prediction

What is CCDF?

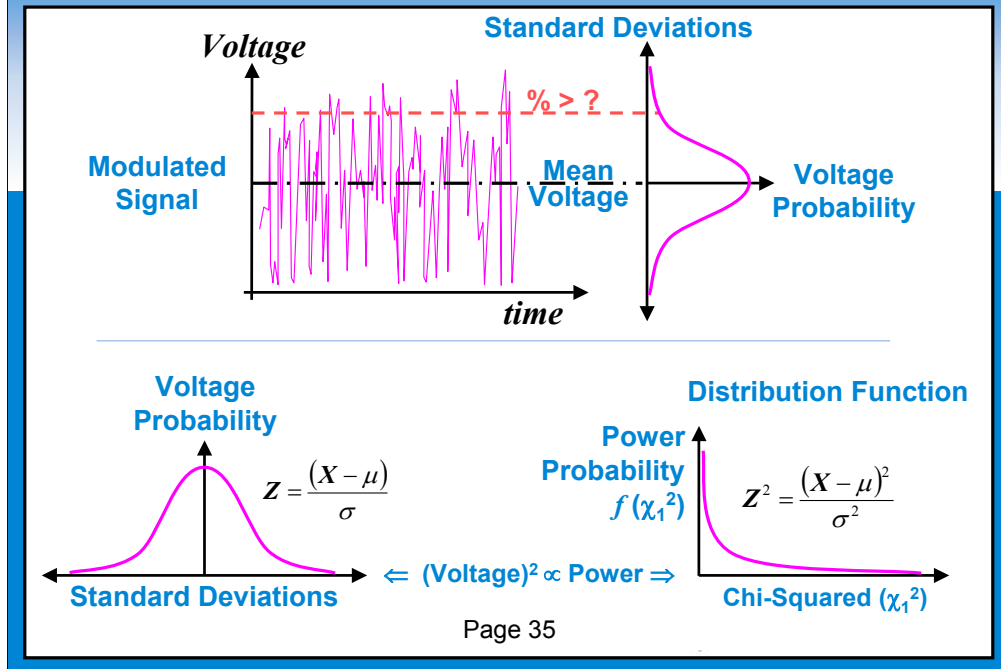

Let's examine CCDF in greater detail, for it is often misunderstood and hence not used as widely as it probably should be.

Say our modulated signal varies voltage with time (shown at the top of the slide). If we were to draw the probability of any given voltage and are modulation was "noise like" a Gaussian like probability distribution would result. To relate this distribution to power instead of voltage, it would be necessary to square it. Squaring the distribution function gives a new distribution function called the Chi-squared distribution. Notice, that it is never negative as the case with power.

Though interesting, the Chi-squared distribution only shows the probability of a given power level and is not directly useable for our correction factors.

Residual BER Prediction

What is CCDF?

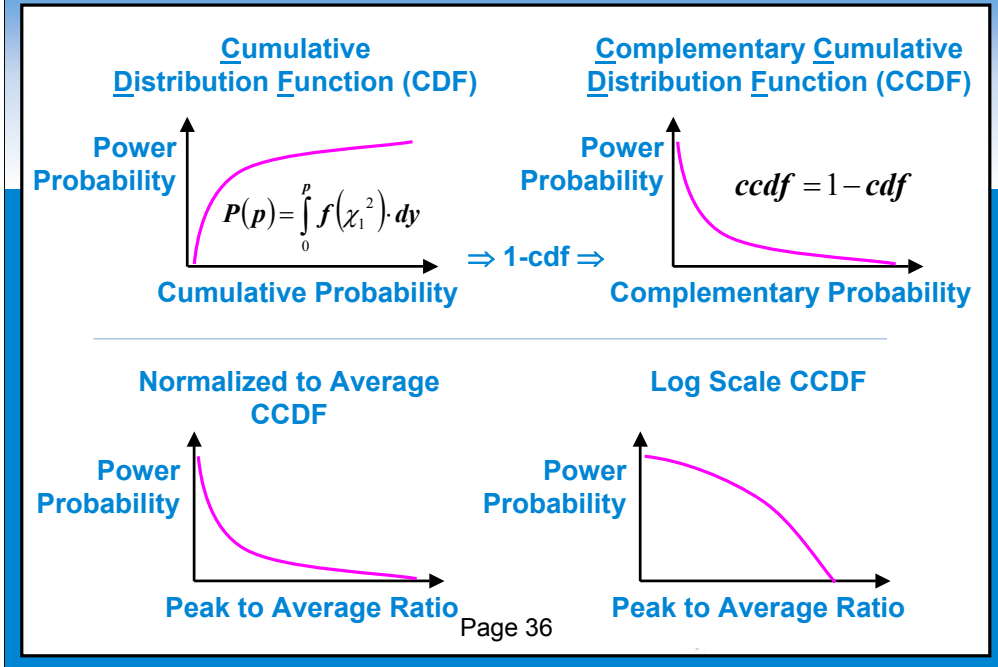

We are interested in when the signal level exceeds a particular level above the average power, so we must perform some manipulation.

If the Chi-squared distribution is integrated, the resulting function indicates the the probability of the power being below the upper integration limit. This integrated function is called the Cumulative Distribution Function (cdf).

To characterize the vector range, we are interested in how likely the power is above a given level. Thus if we subtract the cdf from 100% probability, the resulting "Complementary" Cumulative Distribution Function (ccdf) indicates how likely the power is to exceed a given level. Though close to the desired form two additional manipulations are needed.

First, we want to normalize the function to the average power or the same thing a power meter would read. Finally, it would be most convenient if this peak to average ratio was in terms of dB, so the log of the curve must be plotted. This is the ccdf curve displayed on the measurement equipment.

Residual BER Prediction

CCDF Display

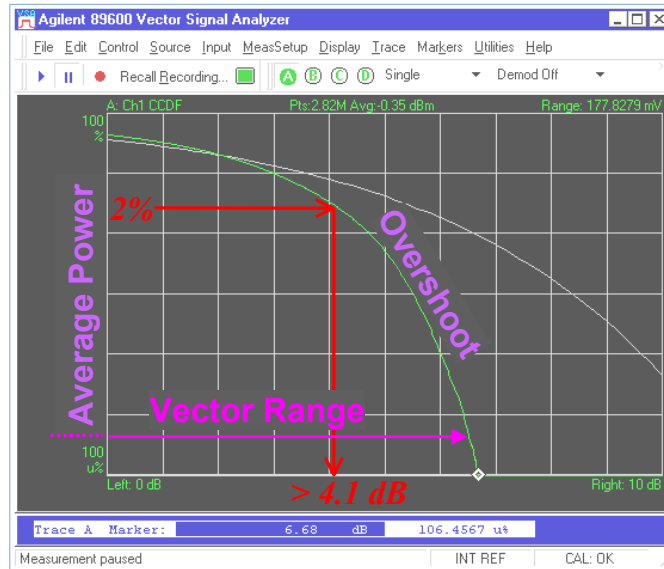

Page 37



Agilent Technologies

Here is an example of the CCDF curve as measured on the 89641 vector signal analyzer. On the vertical axis, we have the % of time the signal exceeds a given level. On the horizontal axis, the number of dB above the average power is displayed.

There are two curves shown. The gray curve is the ccdf relationship of pure Gaussian noise. The green curve is the ccdf relationship of a 64 QAM signal without PA distortion (as measured directly out of the modulator). The left most vertical axis intersects the horizontal axis at the average power or that which the power meter would read. The distance from the left most vertical axis to the green curve represents the vector range! This presents a bit of a problem? The vector range is dependent on the percentage of time one is interested in!

For example, 2% of the time the vector range exceeds 4.1 dB above the average power a power meter would read of the modulated signal. So now the question becomes what percentage of time should we use?

Residual BER Prediction

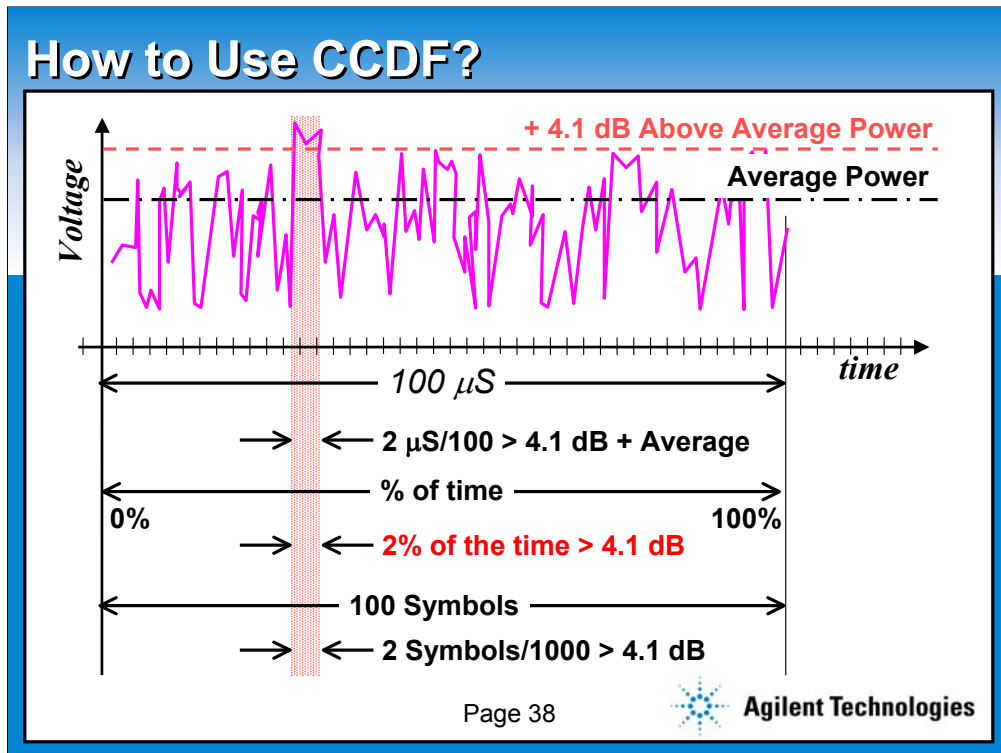

The answer to what percentage of time to use is very much dependent on our system goals. Say, we have 100 μ S of modulated data, the 64 QAM ccdf curve shows us that we should expect for 2 μ S the power to exceed 4.1 dB. This is the same as saying that 2% of the time the signal exceeds 2.5 dB above the average power. This also means that if the modulated signal contained 100 symbols, a period of time equivalent to 2 symbols the power would exceed 4.1 dB above the average. This means that 2 out of every 100 symbols would drive the power amplifier to a level exceeding 2.5 dB above the average. Said another way, 2 out of every 100 symbol times will suffer a degradation 4.1 dB above the average.

The systems engineer must determine how many symbols can be allowed to suffer a given degradation. If a BER of 10^{-6} was desired, 1 bit in every 1,000,000 sent would be of interest. Using a 64 QAM signal that sends 6 bits per symbol this would allow 1 symbol error in every 166,667 sent to be made (assuming only a single bit error per symbol error, adjacent gray coded states). $1/166,667$ is 5.9×10^{-4} percent of the time or 0.59 m% of the time, which can be read from the log scale on the vertical axis of the ccdf curve!

Thus the system engineer sets the vector range based on the data quality that must be protected or the statistical frequency in which the vector range could be allowed to damage a limited number of symbols. In practice, the ccdf curve's shape which is a function of the modulation often gets so steep that it can be assumed to asymptotically approach a limit where the power will never exceed a given level.

Residual BER Prediction

Spot vs. Swept Measurements

- Swept Power, Single Frequency
- Swept Frequency, Single Power Delta Step
- Swept Frequency P_{Output} & ϕ Cal. at Minimum Power!
- Swept Frequency Test at Overshoot Power!

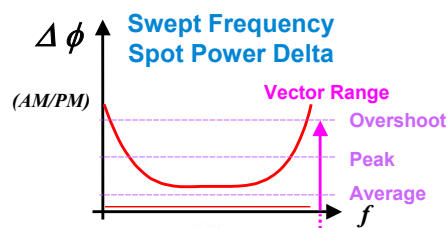
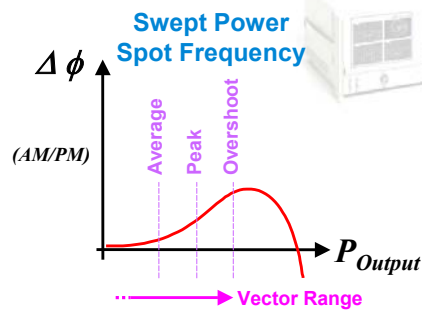

Page 39



Agilent Technologies

There are two types of AM/PM measurements, spot and swept. The classical diagram of AM/PM or $\Delta\phi$ versus power level, often seen in linearizer work, is a spot frequency versus swept power measurement. This measurement is best suited for fixed frequency operation since the matching, hence AM/PM, is usually a function of frequency.

Another approach is to use a swept frequency measurement at a spot power delta. This measurement is best suited for broadband devices that operate over a range of frequencies. It does require the assumption that the AM/PM increases monotonically over the power range of interest which is virtually always the case for QAM signals.

Swept frequency AM/PM measurement requires the PA output power to be calibrated across the band of interest at a low power (power cal). Next, the phase is calibrated to zero with the PA in place (since this is a relative measurement). Finally, the power is increased to the overshoot power and the AM/PM across the band can be observed.

Practically, AM/PM measurement must be done quickly to avoid junction cooling effects that influence the accuracy of the measurement. If it is not possible to make the measurement quickly the more complicated complex stimulus/response method is required let's see why.

Residual BER Prediction

Thermal Considerations

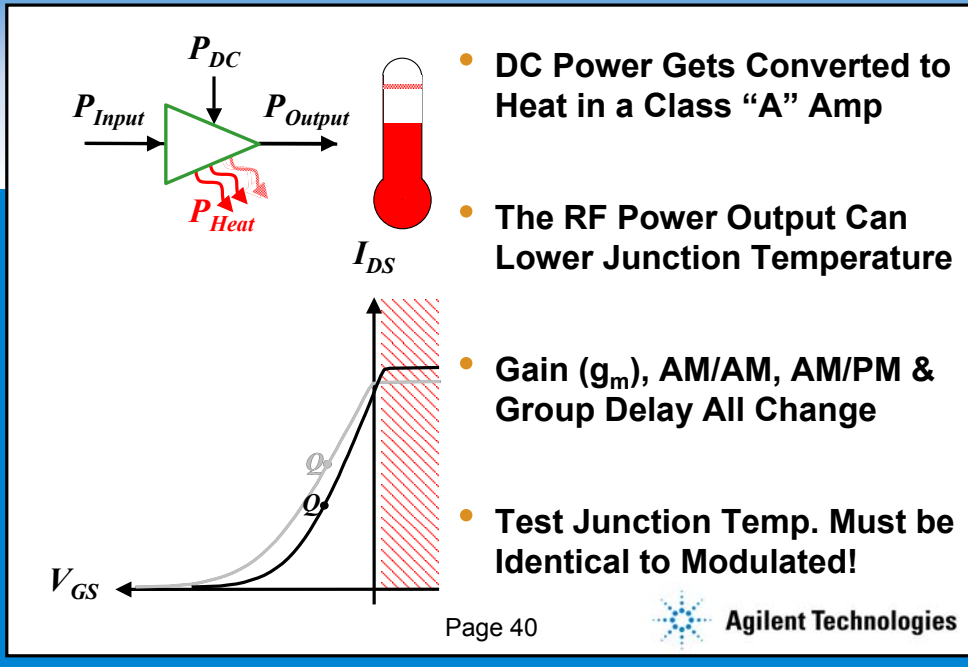

Imagine a high powered amplifier designed to give very linear amplification even up to many watts of output power. Such an amplifier might be a class "A" amplifier biased on a Q point so DC current is constantly flowing and linearity is optimized. Such an amplifier might take in 100 watts of DC energy. In the absence of an RF input signal to amplify, all 100 watts would be dissipated in the semiconductors junction.

When a RF input signal is applied it will be amplified and RF energy will emerge from the output of the amplifier. The amplified RF energy is transformed from the raw DC energy supplied to the device. Thus no longer are all 100 watts dissipated in the junction as heat, some, maybe 20 watts, of energy is transformed to a powerful microwave signal that leaves the device and 80 watts are dissipated in the junction. This means as the RF output increases, the junction of the device actually cools!

There are many properties of semiconductors that are very temperature dependent. Large percentage temperature changes of the junction will change gain, g_m , AM/AM, AM/PM, group delay to name a few. It is therefore essential that large percentage changes of junction temperature from the normal modulated signal are avoided for accurate device characterization.

Residual BER Prediction

Which Analyzer to Choose?

- VNA's use Swept Sine-wave Stimulus

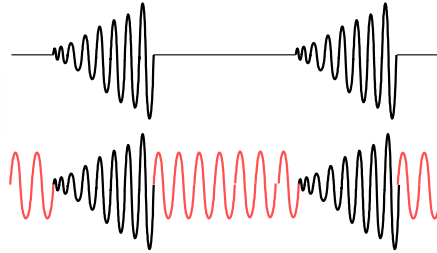

- Consider an "Idling" Power & Fast Sweeps

- Vector Signal Analyzer & Complex Stimulus

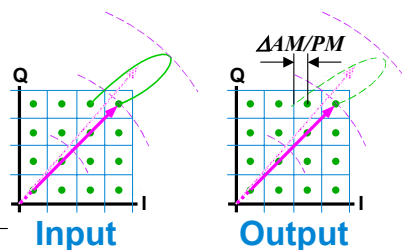
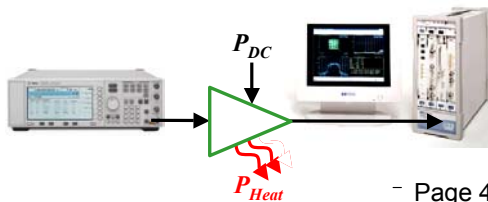
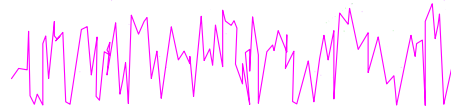

- Page 41 -

Vector network analyzers (VNA's) use a swept sine-wave stimulus of the Device Under Test (DUT). This stimulus is often associated with a long "dead" time between measurement sweeps. Depending on the thermal characteristics of the power amplifier's junction, this can give rise to a significant amount of measurement inaccuracy relative to a continuous modulated signal junction heating.

When the device properties and cooling effect are such where the thermal properties can influence the measurement accuracy it is usually easy to detect. A swept frequency, single power delta will usually reveal an AM/PM measurement that slowly changes as the junction temperature varies.

If this is the case, often, the problem can be mitigated by using an "idling" power that approximates the correct junction temperature and then making the measurement sweep as fast as possible so the junction doesn't have time to significantly change temperature. An important VNA trait to look for that enables fast AM/PM measurements is a low phase noise in the VNA stimulus source. This eliminates the need for narrow IF bandwidths that force slow sweep times.

In some cases, the thermal issues or average AM/PM across a band (common in multi-carrier AM/PM measurements for pre-distortion) require a complex stimulus such as the real modulation and a vector signal analyzer to measure the AM/PM between the modulated input and modulated output.

Residual BER Prediction

Residual BER Prediction

- QAM Digital Radio
- Noise & Error Probability
- Non-Linearity Distortion
- **System Cost Considerations**
- Example Measurements

- Page 42 -

Now that we have reviewed some of basic the principles behind QAM digital radio, a phase noise probability model and non-linear elements, let's review some of the mathematics necessary to combine them and the cost considerations that they drive.

Residual BER Prediction

Quiz – Polling Question #3

Error Vector Magnitude (EVM) measurements are a faster means to predict BER for?

- A) all received signal strengths
- B) only near receiver threshold
- C) when summing component contributions
- D) EVM is not useful for predicting BER



Residual BER Prediction

Noise & Distortion

- Distortion is Directly Additive to Noise! (Offsets μ)
- Distortion is Deterministic & Has No Error Probability!
- Residual BER is a Function of BOTH the PA and Sources!

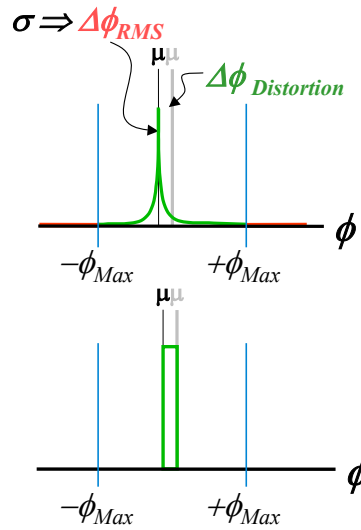

Page 44



Agilent Technologies

Distortion is directly additive to the noise because it operates on the vector itself. This has the effect of offsetting the mean value of the probability density function.

Distortion by itself has no probability of an error! At first this might seem counter intuitive but it requires the randomness of phase noise to create random dribbling errors. What if the distortion was so large that sample point fell beyond the symbol boundary? It would make an error, but without noise it would always make the same error in a deterministic way (non-varying BER). This just doesn't happen because there is always some noise present.

Residual BER is a function of BOTH the power amplifier linearity and the phase noise of all the sources in the system! This is a very important point, for often there is disagreement over whether the PA or one of the sources is to blame for dribbling errors. The answer is that they both influence the error floor and only a judicious allocation budget (usually based on implementation cost) can sort out which element is bringing the system down.

Residual BER Prediction

System Phase Noise

- **Outer Symbols Tolerate the Least Angle Error!**
- **Maximum Angular Error Is Dependent on Symbol Location**
- **Total RMS Phase Noise is the Geometric Sum of All Sources**

$$\Delta\phi_{RMS_{Total}} = \sqrt{(\Delta\phi_{RMS_1})^2 + (\Delta\phi_{RMS_2})^2 + \dots}$$

- **Residual BER is a Function of BOTH the Modem & RF Sources!**

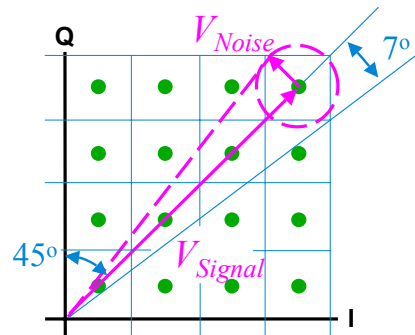

Modulation	Error
2QAM	90.0°
4QAM	45.0°
16QAM	16.9°
32QAM	10.9°
64QAM	7.7°
128QAM	5.1°

Page 45

System phase noise can be represented by a noise vector which adds geometrically to the desired modulation vector. Noise from more than one source can be added geometrically to obtain the total noise for the system.

The sources in the modem and the conversion process all contribute to the overall system phase noise. Thus, residual BER is a function of BOTH the modem and RF sources. The residual BER is effected by BOTH transmitter and receiver sources! These are very important points! It is not possible to evaluate the system residual BER without both the modem and the RF. Likewise it is not possible to evaluate the system residual BER without both the modulator/transmitter and receiver/demodulator.

This means that loop back testing to exonerate the modem from dribbling error problems is not a valid approach.

High quality of service systems require parametric testing of the primary phase noise and distortion components to guarantee consistent interchangeable part performance. As the modulation complexity increases and the minimum permissible angular error decrease careful characterization becomes essential.

Residual BER Prediction

Residual BER Budget Process

- Calculate Maximum Angular Error $\Delta\phi_{Max}$
- Allocate ($\Delta\phi_{Distortion}$) & ($\Delta\phi_{RMS}$)

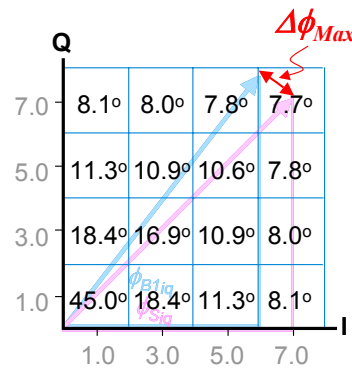
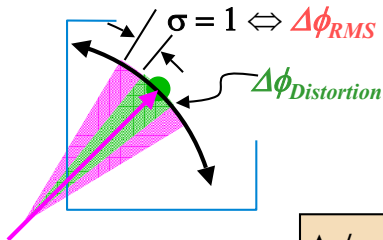

$$\Delta\phi_{Max_{iq}} = \sigma \cdot \Delta\phi_{RMS_{Total}} + \Delta\phi_{Distortion_{iq}}$$



The first step in predicting residual BER is to calculate the symbol vector lengths for every point in the constellation. Using symmetry simplifies the work by only requiring the computations for a single quadrant. This yields the hypotenuse length that is needed for the maximum allowable phase error.

(Note—In some systems with ultra clean sources or where highly accurate BER prediction is required, PA non-linearity maybe significant enough to require accounting for AM/AM effects. This can be done by calculating the how much the vector length is shortened and applying it to the calculated hypotenuse length.)

Second, the maximum possible phase error for each symbol is calculated.

Third, the phase noise and distortion components are allocated on a trial basis, and as we will see, this allocation can greatly effect system cost.

(Note—The first Agilent Residual BER web-cast covers the mathematics in greater detail than this presentation.)

Residual BER Prediction

Residual BER Budget Process

- Calculate Number of σ to the Boundary

$$\sigma_{iq} = \frac{(\Delta\phi_{Max_{iq}} - \Delta\phi_{Distortion})}{\Delta\phi_{RMS_{Total}}}$$

- Calculate Symbol Error Probability & BER

Q				
				(σ_{iq})
7.0	8.6	8.3	8.0	7.8
5.0	13.8	13.2	12.6	8.0
3.0	25.7	23.1	13.2	8.3
1.0	70.0	25.7	13.8	8.6
	1.0	3.0	5.0	7.0
	I			

$$P_{iq}(\Phi > \Delta\phi_{Max}) \approx 2 \cdot \int_{\Delta\phi_{Max} - \Delta\phi_{Distortion}}^{-\infty} \frac{1}{\sqrt{2\pi\sigma_{iq}^2}} \exp\left[-\frac{(\phi - \mu)^2}{2\sigma_{iq}^2}\right] d\phi$$



Fourth, the individual symbol error probabilities are calculated from the normalized probability density function by solving the previous equation for the number of sigma to the symbol boundary.

Residual BER Prediction

Bit Error Rate (Probability)

- Calculate the Total Error Probability
- Sum Probabilities & Divide by m Total Symbols

$$P_S = \frac{\sum_{i=1}^4 \sum_{q=1}^4 P_{iq}}{m} = SER$$

- Convert Symbol Error Rate (SER) into BER!

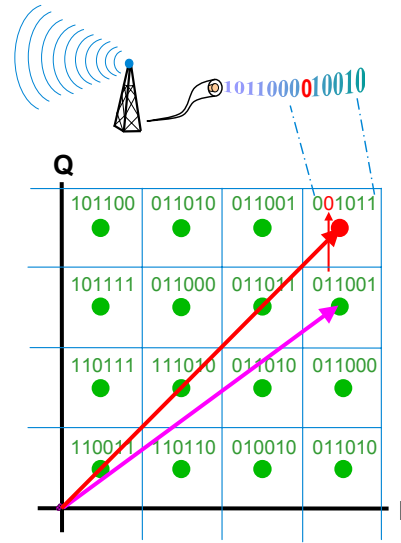

Page 48



Agilent Technologies

Individual symbol error probabilities can be summed up and divide by the total number of symbols to yield the symbol error rate.

The symbol error probability must now be converted to the bit error rate (BER) or probability of a bit error. The conversion of symbol errors to bit errors is bit mapping dependent (i.e. the arbitrary assignment of six different bits to each symbol in the constellation).

Generally speaking, when mapping the bits to symbols, it is important to try to make adjacent symbols differ by as few bits as possible. Ideally, only a single bit differs in the adjacent symbols and a symbol error creates only a single bit error (there is no error multiplication).

The conversion factor between symbol errors and bit errors is typically a low number. Again, the focus is usually on trying to access the order of magnitude rather than the specific number for high QoS systems. Thus in practice with most bit mappings it is usually a close approximation to assume a symbol error results in a single bit error! The symbol error probability calculated is usually a close approximation the BER.

If the overall results are unacceptable, reallocation of the phase noise and distortion components must be repeated until the desired results are achieved. Finally, once the desired residual BER has been achieved the phase noise and distortion allocations must be subdivided across the system.

Residual BER Prediction

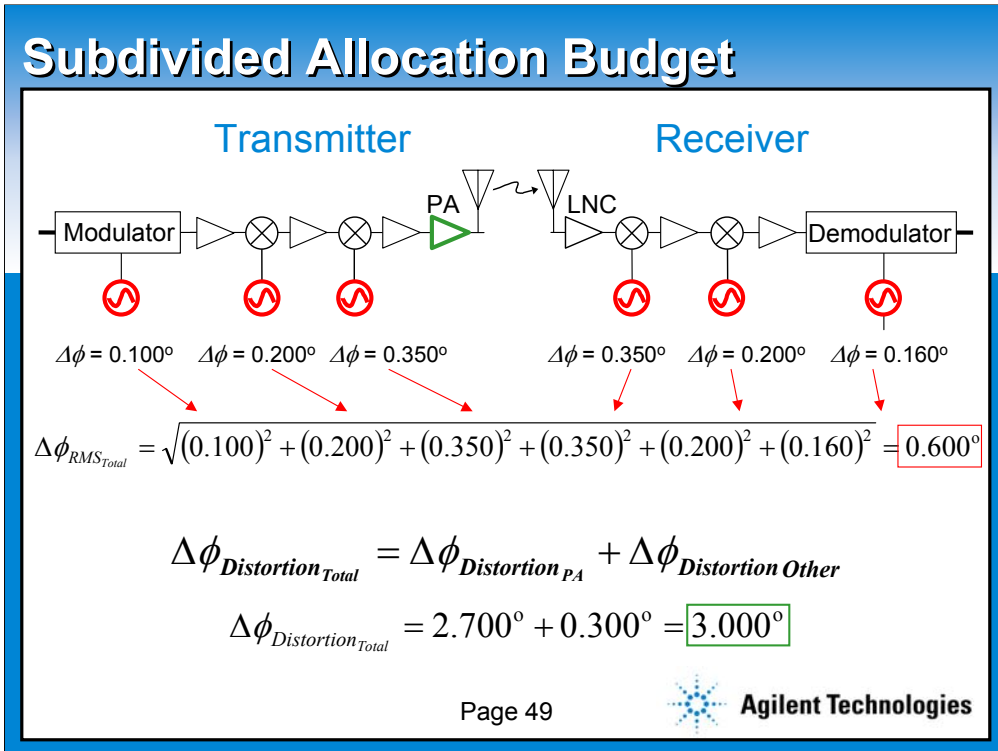

If the calculated BER is acceptable no reallocation of distortion or phase noise is necessary. The final step is to subdivide the total allocation into the components of the system which generate it.

In the case of phase noise, our system has six different sources must total up to the 0.600° allocated. Recalling that noise adds in a RMS fashion, each of the sources integrated phase noise is geometrically summed to add up to the 0.600° allocated. Again the systems engineer chooses the phase noise requirement of each source to minimize cost. The key consideration besides cost, is the $20\text{LOG}(N)$ relationship of multiplied noise (i.e. high frequency sources tend to have more noise than low frequency sources).

A similar subdivision of the distortion budget can be made, but to a lesser extent. It is generally wise to reserve approximately 10% of the distortion budget for secondary effects such as incompletely compensated group delay, PA power leveling, etc..

The skill of the systems engineer in making the right allocations and subdividing the budget into practically realizable values affects the cost and competitiveness of the radio system significantly!

Residual BER Prediction

What is EVM?

Received Vector

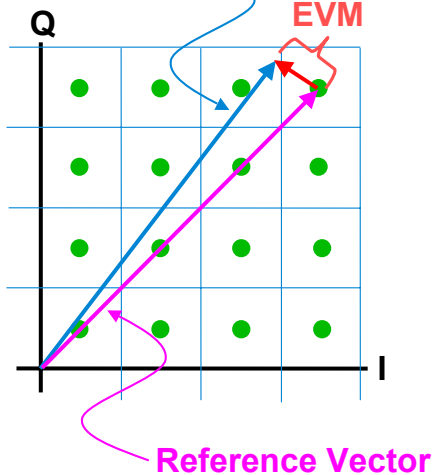

- Error Vector Magnitude
- Popular Modulation Quality Measurement
- Difference Between the Reference Vector & the Received Vector is EVM
- Sometimes Used to Estimate BER?

Page 50



Agilent Technologies

Now that we have reviewed how a residual BER budget is made, let's take a moment and turn our attention to EVM which is often miss applied when it comes to the residual BER problem.

EVM stands for Error Vector Magnitude and is a popular modulation quality metric. EVM is the difference between a reference modulation vector and the actual received vector. It is a measure of how closely the impaired modulation signal matches the reference modulation.

EVM, being an analog measurement is sometimes used to estimate BER. In some cases this quit appropriate and much faster than waiting for an error count. In other cases, EVM does not indicate BER and it is not the correct tool to use. Why?

Residual BER Prediction

Why Not Use EVM?

- Which has a lower BER?
- Which has a lower EVM?

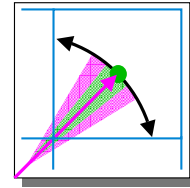

Case I

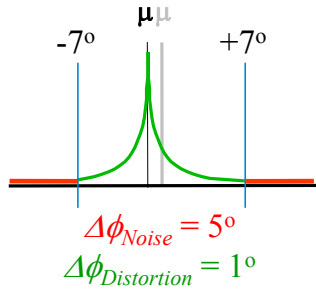

Case II

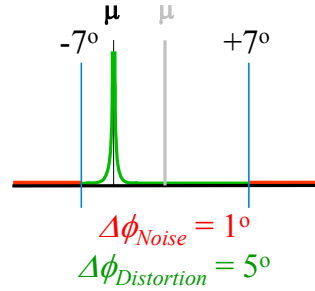

Page 51



Agilent Technologies

To illustrate the issue we have constructed two cases of the outer symbol point of our 64 QAM modulation at the receiver demodulator. Case I, has lots of phase noise and very little distortion. Case II, has very little phase noise and lots of distortion.

Which has lower BER? and Which has lower EVM?

Residual BER Prediction

The Systems Engineer's Choice

- Case I has Lower BER?
- Both have the Same EVM?
- Systems Engineer Choice!
- Money in PA or Sources?
- Residual BER Budget Effects System Cost Significantly!

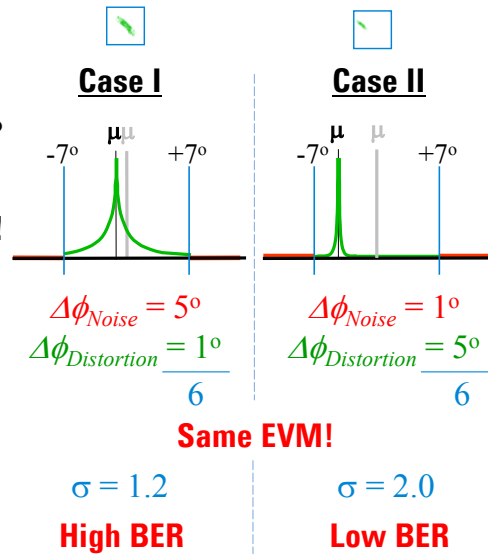

Page 52



Agilent Technologies

It turns out that Case II has lower BER because it has more σ to the symbol boundary ($(7-5)/1=2$). But they both have the same EVM ($5+1=6$ or $1+5=6$). Thus in this case it is not possible to use EVM as a predictor of BER. Something went wrong in the mathematics!

This example also begins to illustrate why the residual BER budget is so critical to system cost. The system engineer has a choice here, to put the money into a more linear PA or lower phase noise sources. Again given these elements typically account for 60% of the radio link's cost this decision could either make the product a smashing success or a high cost failure!

The author has found some companies struggle to meet QoS and cost, while others easily meet the QoS requirements and enjoy solid profit margins. On occasion, one even finds both companies are using the same modem! The difference? One system engineer knows how to pick out a better balance between phase noise and distortion over his competitor.

Residual BER Prediction

Phase Noise versus Linearity

- **EVM = Summation of Deterministic & Probabilistic Effects!**
- **Deterministic Effects (Distortion) Add: $1 + 1 = 2$**
- **Probabilistic Effects (Phase Noise) Add: $1 + 1 = 1.41$**
- **Must Decompose EVM for BER in the Residual Error Floor!**

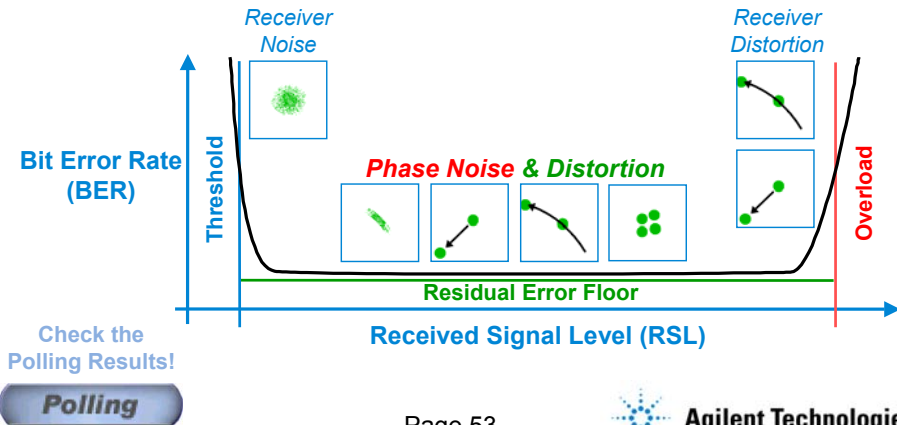

In the previous slide, we saw that EVM did not necessarily predict differing BER. What exactly happened? EVM is the summation of both deterministic effects like AM/PM as well as probabilistic effects like phase noise. EVM does not differentiate between the two types of impairments.

The mathematics of deterministic and probabilistic effects are different however. Deterministic effects such as AM/PM add to our angular distortion budget in a arithmetic $1+1=2$ fashion. AM/PM always rotates the vector in the same direction proportional to the vector magnitude. Probabilistic effects such as phase noise add in a geometric $1+1=1.41$ fashion and rotate the vector randomly in direction. Thus for the residual error floor where both deterministic and probabilistic effects play a role it is necessary to decompose EVM to make a BER prediction.

EVM can only predict BER where only a single type of impairment vastly dominates the QoS performance. This is usually the case around threshold where errors are caused primarily by Gaussian (probabilistic) noise. Likewise, at overload, where receiver distortion dominates (deterministic) EVM will parallel BER.

So be careful when attempting to use EVM as an indicator for BER. OK for threshold and overload, but must be decomposed for the residual error floor! (Note—This also has consequences for using EVM as a residual error floor interoperability metric, a common mistake.)

Residual BER Prediction

Tips for Optimizing Cost

- **Equate Phase Noise and Distortion**
- **As a Starting point:** $\sigma \cdot \Delta\phi_{RMS} \approx \Delta\phi_{Distortion}$
- **Remember 20·Log(N) Effects & Source Cost**
- **Compare Integrated not Spot Phase Noises**
- **Always Validate Modem Oscillator Performance**

Page 54



Now that we have seen that the systems engineer has a choice between allocating product cost to distortion or phase noise, how does one optimize the allocation? This is a complicated subject and usually falls on the many years of experience and judgment of the talented systems engineer. There are a few points which may provide a starting point for those who are new to the subject. For many systems a good starting point in the iterative process of minimizing cost is to equate the phase noise and distortion elements. In our 64 QAM example, $7 \sigma \times 0.600^\circ$ is roughly equal to the 3.00° of PA AM/PM. This gives a reasonable starting point to approach component suppliers and begin to optimize cost.

Another important point to keep in mind is the $20\text{Log}(N)$ multiplication of phase noise. Often we encounter a situation where higher frequency LO's are multiples of low frequency references. When evaluating phase noise performance it is reasonable to expect phase noise to grow by $20\text{Log}(N)$, N being the number of times the reference is multiplied.

When comparing component phase noise, always compare integrated phase noise not just a few spot points. Because the integration process is performed on data normally plotted on a log plot, it is difficult to judge integrated performance from a spot measurement.

Finally, always validate modem oscillator performance. Noise digital environments can significantly degrade performance over separate bench top tests.

Residual BER Prediction

Optimizing Cost

	RMS Phase Noise		Cost	\$/Degree
Modulator	0.10		\$ 10	\$ 100
Tx 1st LO	0.20		\$ 200	\$ 1,000
Tx 2nd LO	0.35		\$ 500	\$ 1,429
Rx 1st LO	0.35		\$ 500	\$ 1,429
Rx 2nd LO	0.20	Total	\$ 200	\$ 1,000
Demod	0.15	Alloc.	\$ 15	\$ 100
Total Phase Noise	0.60	< 0.60	\$ 1,425	

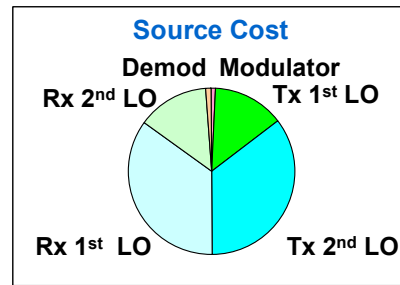
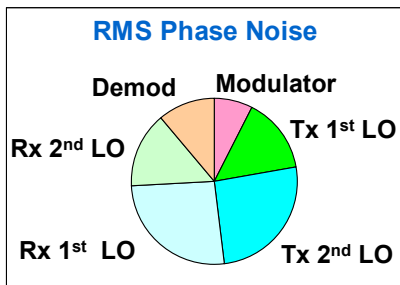

Page 55

Another tool that is useful when it comes time to subdivide the phase noise budget across the system is a simple pair of pie charts. One graph that displays the phase noise the other displays the cost of the phase noise.

It is often helpful to compare the phase noise contribution to the system against its cost. A large phase noise contribution by a low cost source may warrant tightening its performance criteria. Modem oscillators can fall into this category. Inexpensive surface mount crystal oscillators can save a few pennies on the modem assembly, but can require expensive microwave synthesizers to tighten their requirements. The result is the overall system costs go up!

Another useful tool to minimize cost is to calculate the cost per degree of phase noise. The lowest cost per degree maybe the best place to start searching for savings.

Residual BER Prediction

More Information

Example Spreadsheet is Available At:
www.agilent.com/find/rxtx

	A	B	C	D	E	F	G	H	I	J	K	L	M	Form
1	Calculations						Theory							
2	Allocation of Phase Noise & Distortion (Use care!! \$\$\$ Product Economics!! \$\$\$)													
3														
4	Caution! The following allocation can make or break your product economically!													
5														
6														
7	Total System Phase Noise (Degrees RMS) =						0.6000	~ Insert Allocation!						
8	Total System Distortion (Degrees AM/PM) =						3.0000	~ Insert Allocation!						
9														
10	Number of Sigma to the Boundary (Assumes symmetric! Could be off by as much as 2X!)													
11														
12	11.0	3.7	3.6	3.5	3.5	3.4	3.3							
13	9.0	5.6	5.4	5.3	5.2	5.1	3.4							
14	7.0	8.6	8.3	8.0	7.8	5.2	3.5							
15	5.0	13.8	13.2	12.6	8.0	5.3	3.5							
16	3.0	25.7	23.1	13.2	8.3	5.4	3.6							
17	1.0	70.0	25.7	13.8	8.6	5.6	3.7							
18		1.0	3.0	5.0	7.0	9.0	11.0							
19														
20	Probability of Individual Symbol Errors (Assumes Worst Case AM/PM for all Symbols)													
21														
22	11.0	5.5E-03	6.8E-03	8.4E-03	1.0E-02	1.2E-02	1.5E-02							
23	9.0	2.1E-06	4.0E-06	7.2E-06	1.2E-05	2.1E-05	1.2E-02							
24	7.0	6.8E-15	5.3E-14	3.4E-13	1.8E-12	1.2E-05	1.0E-02							
25	5.0	1.6E-39	1.1E-35	1.6E-32	3.4E-13	7.2E-06	8.4E-03							
26	3.0	5.4E-139	5.7E-112	1.1E-35	5.3E-14	4.0E-06	6.8E-03							
27	1.0	0.0E+00	5.4E-139	1.6E-39	6.8E-15	2.1E-06	5.5E-03							
28		1.0	3.0	5.0	7.0	9.0	11.0							
29	<i>(Negative numbers in the above table indicate excessive distortion)</i>													



To find out more, Agilent makes available a variety of tools. This presentation, spreadsheets, reference posters as well as trained applications consultants can assist you in getting the most out of you designs.

Residual BER Prediction

Residual BER Prediction

- QAM Digital Radio
- Noise & Error Probability
- Non-Linearity Distortion
- System Cost Considerations
- **Example Measurements**

Page 57

Now let's look at some specific examples of measurements on a variety of common subassemblies.

Residual BER Prediction

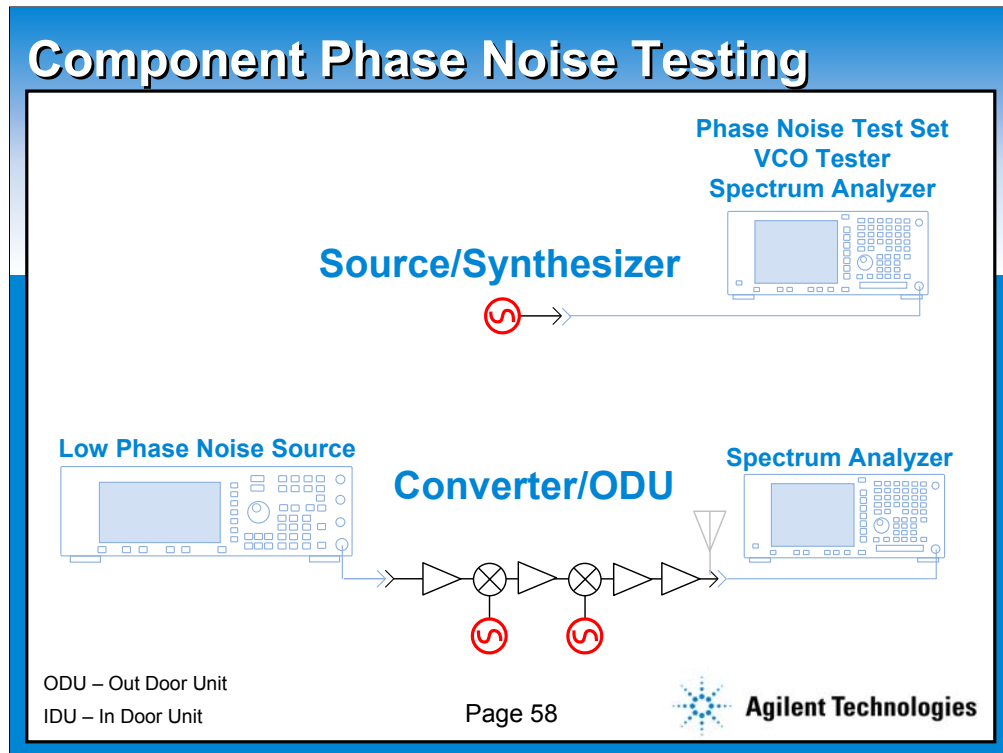

Phase noise testing can take many forms due to the wide variety of device types to be measured.

A simple source or frequency synthesizer is maybe among the most straight forward device to measure. The primary concerns are to select a measurement device capable of measuring the sources phase noise floor, having adequate frequency stability and connectivity access. Devices such as crystal or Yttrium Iron Garnet (YIG) oscillators may require a phase noise test set with excellent phase noise floors. Higher level synthesizers can usually be measured with a spectrum analyzer and software phase noise utility. Unlocked VCO often do not have adequate frequency stability for measurement with a spectrum analyzer and require measurement equipment such as a VCO tester that can lock the VCO, before measuring its phase noise.

Another important consideration for phase noise measurement is the access to the LO, source or synthesizer. Preferably, there is a connector available to measure the signal with sufficient power, if not, it maybe necessary to test larger assemblies.

Converters or ODU's can be tested by injecting a low phase noise signal in the IF or RF and measuring degradation at the output.

Residual BER Prediction

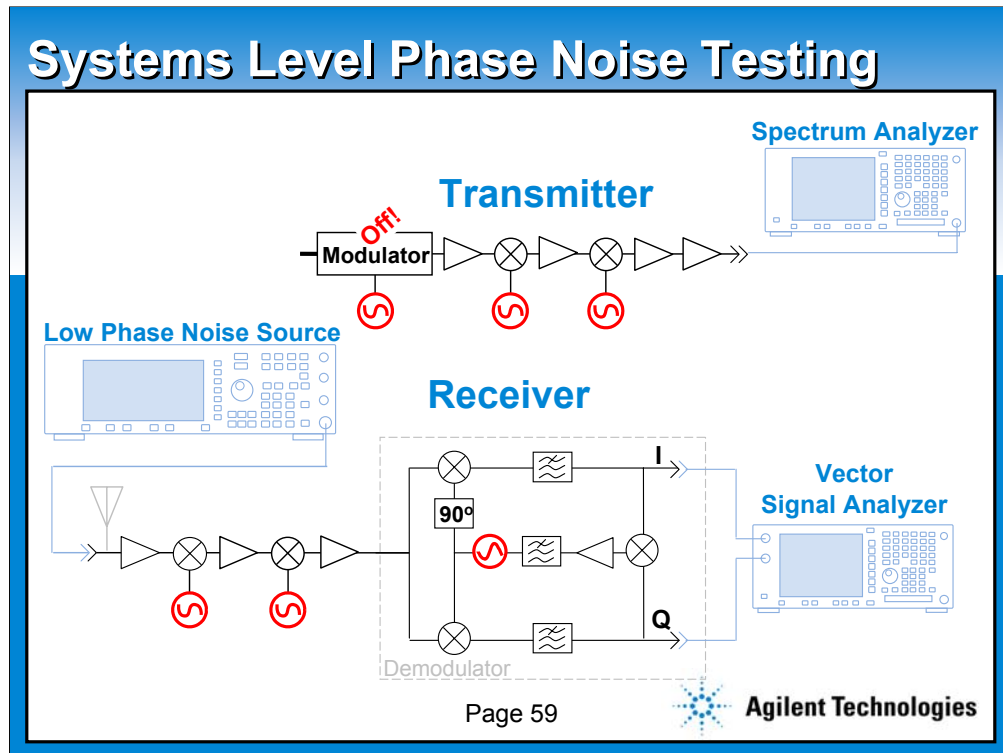

Higher level systems test are also possible for characterizing phase noise. These measurements are often preferable when the goal is assuring interoperability.

Transmitters are easily tested for phase noise if a provision for turning off the modulation has been made (often the case). The carrier is then up converted and amplified to a strong level, ideal for making phase noise measurements. Generally speaking the spectrum analyzer is the preferred measurement tool.

Receivers can also be tested for phase noise by measuring the degradation of a very low noise source signal. Measuring the receiver's has one important difference from the transmitter, it is necessary for the carrier recovery VCO to lock to the test signal, and perform the measurement on I and Q. As illustrated in the diagram above with a simple Costa's loop carrier recovery, the VCO is an important part of the receiver's phase noise measurement. Using a vector signal analyzer with I and Q inputs, the analyzer can reconstruct the base-band signal to measure the phase noise.

As an alternative to entire receiver test using vector signal analyzer base-band I Q inputs, it is possible to measure the phase noise of the down converter portion and then have the receiver lock to a modulated signal to measure the demodulator VCO's contribution separately.

Residual BER Prediction

Phase Noise Measurement Equipment

The diagram illustrates a phase noise measurement setup. It starts with a Modulator, followed by two mixers (represented by circles with an 'X'), a Power Amplifier (PA), a Low Noise Converter (LNC), another two mixers, and finally a Demodulator. Red sine wave icons indicate the injection points for phase noise measurement. Below the diagram, various Agilent instruments are shown and labeled: 89441 (Spectrum Analyzer), E4440A + Opt 226 (Spectrum Analyzer), 856xEC + Opt 85671A (Spectrum Analyzer), ESA + Opt 226 (Spectrum Analyzer), 89641 (Spectrum Analyzer), E5500 (Xtal's) (Phase Noise Test Set), and 4352 (VCO's) (VCO Analyzer).

89441 E4440A + Opt 226 856xEC + Opt 85671A ESA + Opt 226 89641

E5500 (Xtal's) 4352 (VCO's)

Page 60 Agilent Technologies

Agilent of course offers a complete line of phase noise measurement solutions. Popular choices for modem phase noise characterization are our 89441 series up to 10 MHz bandwidth or the 89601A series up to 500 MHz of bandwidth.

Agilent has a complete line of spectrum analyzers with phase noise measurement applications. The economical ESA series is ideal for characterization of inexpensive sources, the 856xEC series is the measurement tool of choice for moderate performance field applications and the E4440 series is excellent for high performance synthesizer characterization with near real time integration of the measurement data.

Specialized applications such as crystal or YIG source measurement are best suited to the flexible E5500 series phase noise test set. VCO's that lack frequency stability can easily be characterized for phase noise and many other important parameters on the 4352 VCO analyzer.

Residual BER Prediction

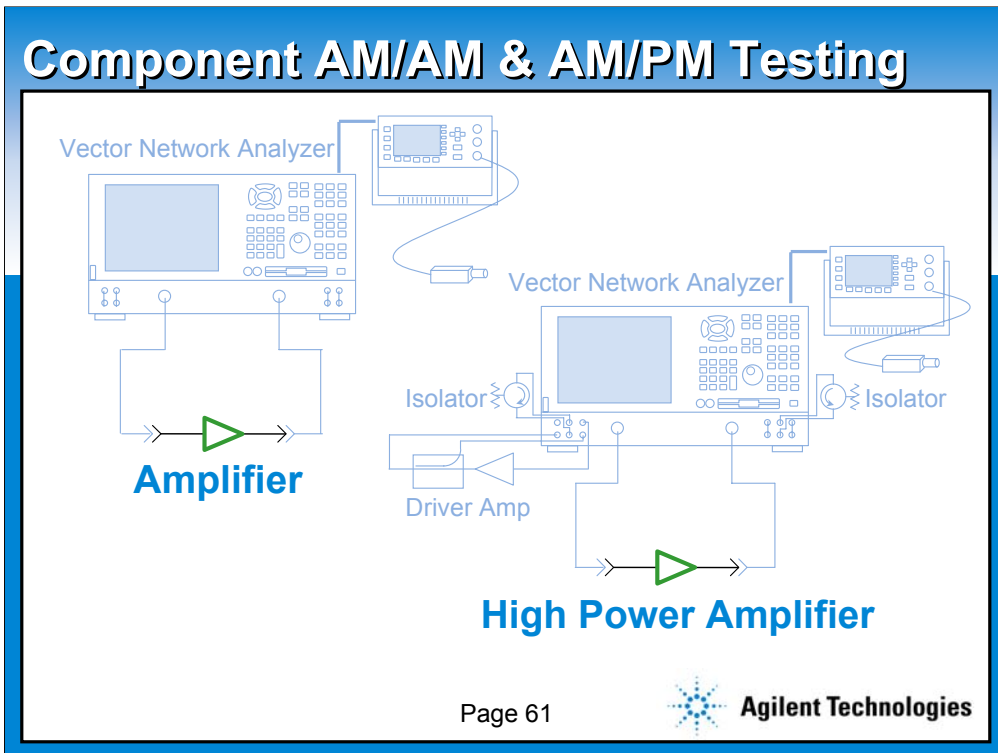

To characterize linearity of components there are a variety of test configurations to suit almost any component, subassembly, assembly or system.

Simple amplifiers or amplifier chains can be connected to a Vector Network Analyzer (VNA). A compatible power meter is essential to properly calibrate the network analyzer. There is a hidden benefit to using a VNA for device linearity characterization, that is it can also characterize S-parameter performance on the same setup! Often without even changing connections.

Modern VNA's can be configured with the addition of a driver amplifier, coupler and isolators to handle high power signals directly, while still retaining the ability to make very accurate S-parameter measurements, particularly S_{22} . Again, this provides both linear and nonlinear characterization.

Residual BER Prediction

AM/AM & AM/PM System Level Testing

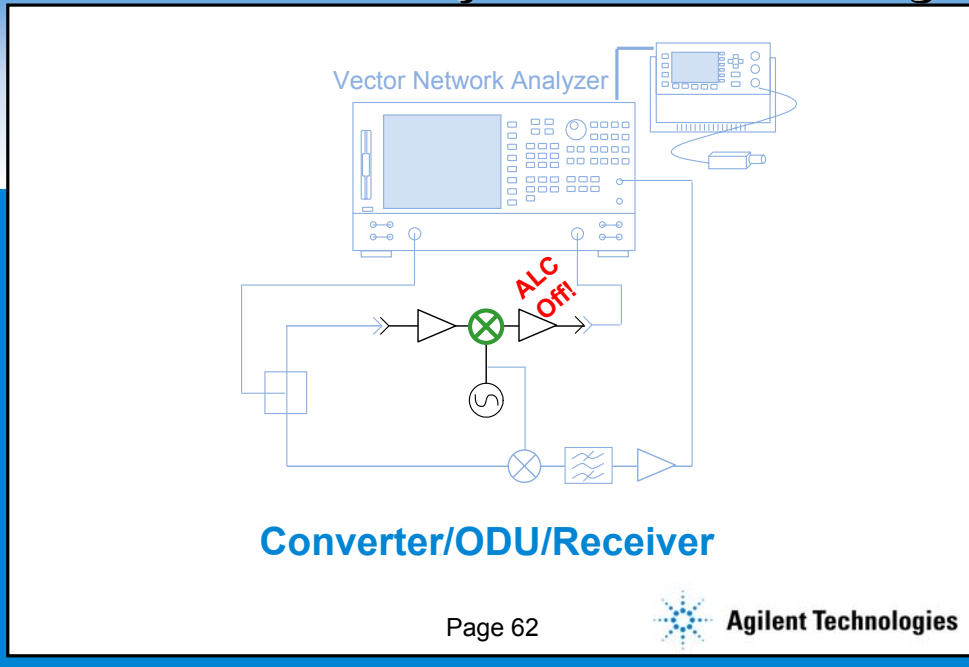

The expense and difficulty of high frequency interconnects often do not allow test connections at intermediate signal points, thus testing requirements can demand linearity testing on frequency converters.

The receiver down converter assembly shown above can be characterized by the addition of an external frequency reference path composed of a mixer, sideband select filter and amplifier. Thus linearity measurements of AM/AM and AM/PM can be performed to determine overload points as well as conversion gain and flatness.

One important consideration when making receiver measurements on complex modulation systems is be make sure any Automatic Leveling Control (ALC) is turned off. ALC can alter the power levels and gain of the DUT.

Residual BER Prediction

AM/AM & AM/PM System Level Testing

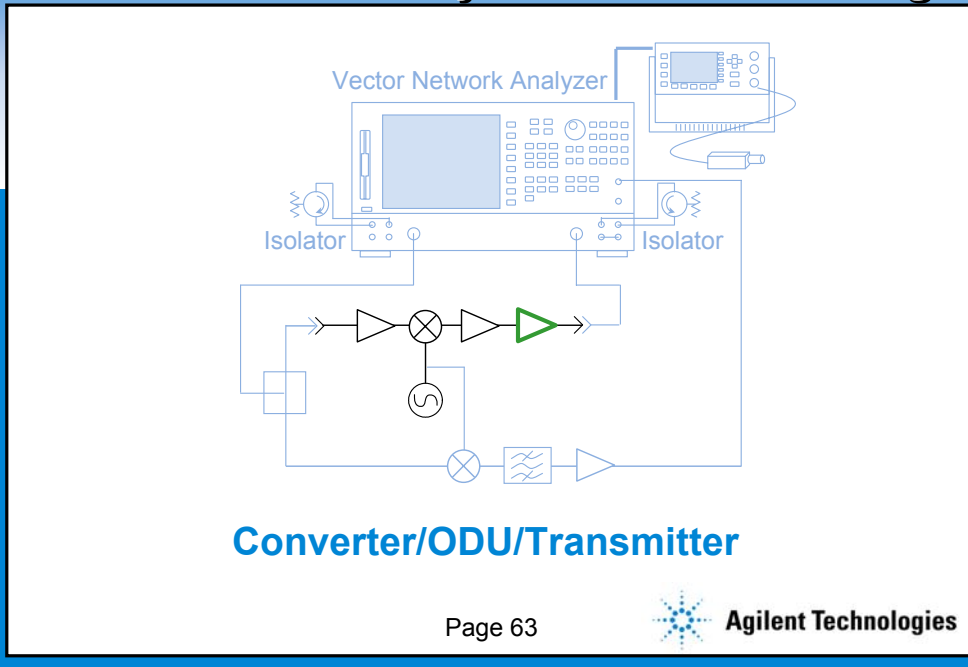

Similarly to the receiver case, converter measurements can be applied to transmitter or ODU applications. Like receiver applications where frequency conversion is involved, it is necessary to create an external phase reference path. This is done with a power splitter, external mixer, filter and amplifier.

There are two main differences between the receiver measurements and transmitter measurements. First, with most transmitter measurements, the power levels required to properly drive the up-converter assembly, are much higher. Care must be taken to assure the reference phase path remains in its linear range well away from where AM/PM effects will begin. Second, with transmitter testing, frequently, the output power levels are quite high. Thus the vector network analyzer often must be configured for high power operation with the addition of some isolators.

At the higher frequencies, it can be advantageous to measure the transmitter assembly with duplexing filter in place. The interaction between this filter and power amplifier can be very significant at the band edges, even with an isolator in place! The VNA is the ideal tool for displaying both the linear and non-linear metrics involved in this interconnection that can rob performance.

Residual BER Prediction

Linearity Measurement Equipment



E4418/19B
for PNA



E835xA



E836xA



872xES



8753ES

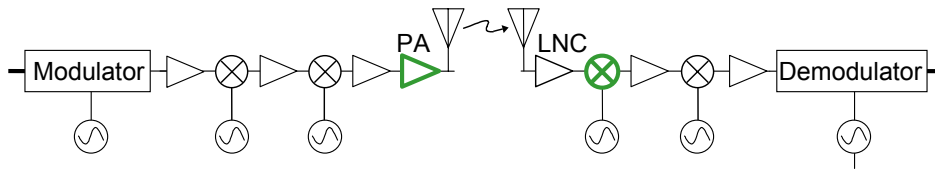

Page 64



Agilent Technologies

Agilent again offers a complete line of linearity measurement equipment ideally suited to measuring AM/AM and AM/PM.

Popular choices are the E835xA analyzers for amplifier applications below 9 GHz or the E856xA for applications to 50 GHz. These analyzers feature modern interfaces, excellent dynamic range and low phase noise sources for rapid AM/PM measurement.

Converter/ODU/receiver/transmitter measurements are fully supported by the 872xES series to 40 GHz and the economical 8753ES series to 6 GHz.

Compatible power meters such as the E4419B and E4419B for calibration are also available from Agilent.

Residual BER Prediction

Golden Unit Testing

- Do NOT Use Golden Units for Residual BER Testing!

Test Fixture

$$7.8 \cdot (0.10^2 + 0.20^2 + 0.35^2)^{-2} + 3.00 + 7.8 \cdot (0.25^2 + 0.10^2 + 0.05^2)^{-2} \leq 7.69^\circ$$

Field

$$7.8 \cdot (0.10^2 + 0.20^2 + 0.35^2)^{-2} + 3.00 + 7.8 \cdot (0.35^2 + 0.20^2 + 0.15^2)^{-2} \leq 7.69^\circ$$

Transmitter
Receiver
BER

- Page 65 -

One last important point when it comes to characterizing residual BER, do not use “golden” units for testing. Why, as we mentioned before the residual BER is a function of many factors distributed across the system adding together in a complex way. If the total is in excessive of the maximum allowable angular error the BER will be too high. The difficulty for using golden units is obtaining ones with sources and amplifiers that have the worst case phase noise and distortion, a difficult proposition to construct. In fact, often when it comes to choosing a golden unit, a “good one” is chosen that likely has lower than average phase noise and distortion.

Another key issue with using golden unit testing is there are no quantitative parametric data generated. This makes it impossible to predict compatibility with other units without retesting. In addition, the go/no go nature of golden unit testing provides little value when it comes to statistical process control, because of its poor resolution (pass/fail) and inability to separate differing impairments.

So remember. Do **NOT** use Golden modems as part of your production process when you measure Residual BER. The “Golden” modem, with its better than normal performance can easily mask other problems in your radio chain, causing a unit to pass in production that dribbles errors during operation in the field!

Residual BER Prediction

Conclusions

- **Radio Cost is a Strong Function of the Residual BER Budget!!!**
- **A System's Budget is Essential Part of Predicting Residual BER**
- **Diagnosing the Error Source Requires a System's Budget**
- **Residual BER can be Predicted from**
 - **Spectrum Analyzers Measurements of Integrated Phase Noise**
 - **Vector Network Analyzer Measurements of AM/PM, AM/AM**
 - **Signal Analyzer Measurements of CCDF**
- **Equipment to Character Devices & Systems is Available from Agilent!**

Page 66



The residual BER budgeting process is a key analysis in producing a cost effective wireless data link that meets the quality of service requirements demanded by the network provider. Using a combination of phase noise and AM/PM distortion measurements, the sources and PA can be characterized to deliver consistent combined residual BER performance by constructing a worst case residual BER budget. The sound residual BER budget allows diagnosis of a variety of vexing system level problems.

Residual BER can be predicted from spectrum analyzer and vector signal analyzer measurements of phase noise. Specialty applications may demand a phase noise test set or VCO test set.

The linearity portion of the budget can be measured using a vector network analyzer. A variety of interconnection approaches allow test of virtually any popular device, subassembly or assembly. Specialty applications are also supported by complex stimulus sources and response equipment such as the vector network analyzer.

CCDF necessary to determine the vector range is easily measured with a variety of signal and spectrum analyzers.

Agilent also supports your goals by providing a complete line of equipment for these needs.

Residual BER Prediction

More Information

Predicting Residual BER II:

- Presentation/Notes **New**
- Application Note **New**
- Spreadsheet
- Measurement Tips Poster **New**
- Predicting Residual BER I

Available at:

www.agilent.com/find/rxtx

Questions or Comments Contact:

kent_k_johnson@agilent.com



Page 67



Agilent Technologies

To find out more, Agilent makes available a variety of tools. This presentation, spreadsheets, reference posters as well as trained applications consultants can assist you in getting the most out of you designs.

Residual BER Prediction



Thank You!

Page 68



Agilent Technologies

This paper has covered the process for predicting the residual BER from the analog metrics which influence it. Accurate characterization of these metrics is an essential part of providing the most system for the money and Agilent has a complete line of products to assist you in developing and optimizing your design as well as controlling it in production!